



Filter driers

→ DCY-P6 / 64 bar (928 psig)

■ Applications

- Filtering and drying of refrigerants for liquid lines of refrigerating and air conditioning installations, running with high working pressures.



64 bar

CO₂ SUBCRITICAL

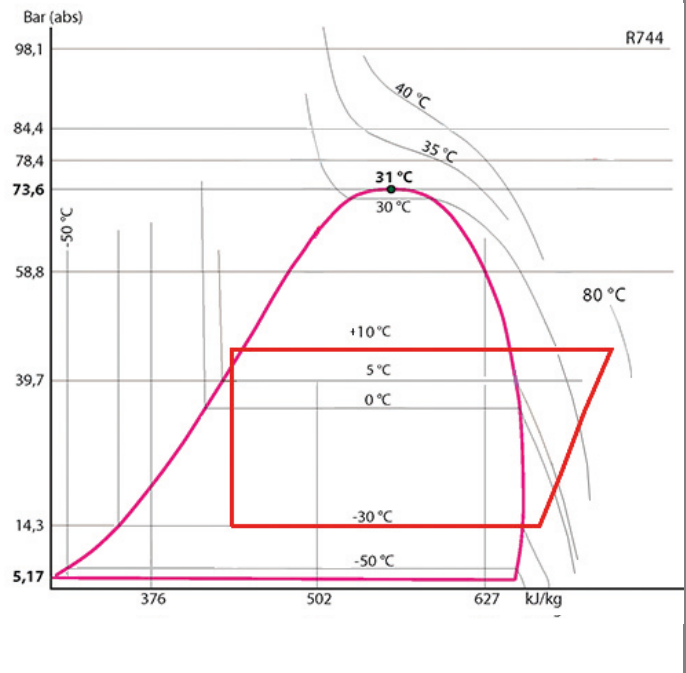

■ Functional features

- Products are compatible with HFC, HFO and CO₂, as well as with their associated oils and additives. Products are designed for use of non-hazardous refrigerants from group 2 of PED 2014/68/EU.
- Product classification in CE categories is done with the PED 2014/68/EU table, corresponding to a volume-based selection.
- Hermetically sealed outer steel enclosure with paint to ensure a high resistance to corrosion.
- Filtering at outlet preventing propagation within the circuit of particles bigger than 25 microns, with a very low pressure drop.
- No desorption, even at a high temperature.
- Several types of connections are possible on standard products:
 - To be screwed type SAE
 - To be brazed for tubes in inches (S)
 - To be brazed for tubes in millimeters (MMS)



Possible customization on demand:

- Specific connections (O-RING, ORFS, ...)
- Stainless steel casings and unions (resistance to corrosion and at low temperatures).

■ CARLY advantages

- Maximal working pressure: up to 64 bar with CO₂ in subcritical compression systems.
- Great drying at all temperatures, thanks to a rigorous selection and a judicious mix of the chemical agents present in the filter driers (activated alumina in order to neutralise the acids and molecular sieves to adsorb moisture); the volume of free-grains drying agents used in a CARLY filter drier is greater than that present in an equivalent model with a solid core.
- Initial drying capacity guaranteed by a 200 °C oven drying and airtight sealing.
- Drying ensured for the subcritical CO₂ applications at low temperatures.
- A dispenser located at the inlet ensures optimal distribution and permanent treatment of the whole refrigerant, inside the filter drier.
- The copper-plated steel connections facilitate the brazing and allow using brazing alloys with a low silver percentage.



Filter driers

→ DCY-P6 / 64 bar (928 psig)

■ Warning

Before selecting or installing any component, please refer to the chapter 0 of CARLY technical catalogue - **WARNING**.

■ General assembly precautions

The installation of a component in a refrigeration system by a skilled professional, requires some precautions:

- Some are specific to each component,
- Other are general to all CARLY

and in this case, they are specified in the **RECOMMENDATIONS SPECIFIC** part defined hereafter ;

components, they are presented in the chapter 115 of CARLY technical catalogue – **GENERAL ASSEMBLY PRECAUTIONS**.

■ Recommendations specific to DCY-P6 filter driers

- Filter driers are to be mounted on the liquid line between the receiver and the expansion element.
- The refrigerant flow direction is indicated by an “IN” mark in the inlet shell of the filter drier and by an arrow on the filter drier tag. It must be necessarily respected.
- We recommend the vertical mounting of the filter drier with a top-down fluid flow direction in order to favour its filling when in operation and a rapid flow of the fluid when the installation is shut down.
- We recommend the use of a brasing at 10 % silver minimum for the brasing of the copper coated silver unions.
- Be careful to properly select the solenoid valves located downstream of the filter driers; their over-sizing could cause liquid hammer phenomena hindering the filter driers’ mechanical behaviour; protection of regulation elements located upstream of the evaporator should be performed with FILTRY-P9 (90 bar) dirt filters (refer to chapter 11 of CARLY technical catalogue); these liquid hammer phenomena can originate from other sources, in longpiping installations.
- Never install the filter driers in an area of the circuit that can be isolated.
- Never trap the refrigerant in its liquid state (between a check valve and a solenoid valve, for instance).
- The filter driers must be changed :
 - after each intervention on the installation requiring the opening of the circuit
 - when the liquid indicator indicates an abnormal humidity content
- when the pressure loss measured in the dewatering filter is too high
- at least once a year as a measure of precaution
- Filter drier efficiency and refrigerant moisture content should be checked using liquid sight glasses.
- Make sure that the piping can support without deformation the weight of the filter drier ; otherwise, plan the attachment of the filter drier with a clamp on a stable part of the installation.



Filter driers

→ DCY-P6 / 64 bar (928 psig)

■ Special precautions for components used with CO₂ in subcritical and transcritical systems

- The maximal working pressure and the power variations of the installation must be taken into account as of its design, in order to select all the components consequently.
- The pressure of the circuit during the stop phases must also be taken into account, because it can be very high, due to the pressure equalization according to the ambient temperature; several solutions exist to limit and control this pressure when the installation is stopped.
 - Design of the installation allowing to resist to this pressure.
 - Implementation of a « buffer » volume of storage or expansion (receiver).
 - Installation of a secondary circuit with valve or solenoid valve, allowing the fluid transfer to the coldest point, or the less high in pressure of the installation.
 - Implementation of a small separate refrigeration unit, to maintain the liquid temperature at a pressure lower than the maximal working pressure ; it is so far the most effective technical solution, but with a major drawback, which is the power failure (safety unit to be considered, or backup power supply).
- The hot gas defrost, frequently used with CO₂ for low temperatures applications, generates also high pressures (to take in consideration)
- The implementation on the liquid line of a filter drier **DCY-P6** is highly recommended. Serious problems can occur in the presence of moisture, such as expansion valve blocking and formation of dry ice and even carbonic acid. To avoid this, it is imperative to limit the circuit openings in order to avoid air introduction, causing the condensation in the pipes, and to proceed to a high evacuation of the installation, before any commissioning or restarting.
- For an operation with CO₂ at low temperature, provide thermal insulation on the components which can be covered by frost.
- There is no incompatibility between CO₂ and the main metallic materials commonly used in refrigeration systems (steel, copper, brass...)
- On the other hand, there is a real compatibility issue between CO₂ and polymers. For example, swelling phenomena and internal explosion of the seal are possible. Carly **filter drier DCY-P6** do not have polymer gaskets directly in contact with CO₂.



Filter driers

→ DCY-P6 / 64 bar (928 psig)

■ Selection table: Group 2 fluids (A1, A2L)

CARLY references	Connections		CARLY references	Connections To solder ODF mm	Refrigerating capacity kW ⁽¹⁾					Dehydratable refrigerant capacity kg of refrigerant ⁽²⁾						
	To screw SAE inch	To solder ODF inch			R22 R1233zd	R134a R407C R410A R407F	R404A R507A R452A	R1234ze R513A R448A R449A R450A R455A	R744 CO ₂	R22 R450A R134a R1233zd		R407F R452A R407C R513A R1234ze		R404A R507 R455A R410A R448A R449A		R744 CO ₂ ⁽³⁾
										24 °C	52 °C	24 °C	52 °C	24 °C	52 °C	
DCY-P6 053	3/8				22,8	23,5	16,0	20,4	25,8	9,5	9,0	9,0	8,6	8,5	8,0	5,8
DCY-P6 053 S		3/8	DCY-P6 053 MMS	10	22,8	23,5	16,0	20,4	25,8	9,5	9,0	9,0	8,6	8,5	8,0	5,8
DCY-P6 164	1/2				41,5	43,0	32,0	37,4	46,5	40,0	34,0	38,1	32,4	35,7	30,3	24,3
DCY-P6 164 S		1/2	DCY-P6 164 MMS	12	41,5	43,0	32,0	37,4	46,5	40,0	34,0	38,1	32,4	35,7	30,3	24,3
DCY-P6 305	5/8				70,0	72,0	51,0	62,6	78,4	70,0	61,0	66,6	58,0	62,4	54,4	42,5
DCY-P6 305 S/MMS		5/8	DCY-P6 305 S/MMS	16	70,0	72,0	51,0	62,6	78,4	70,0	61,0	66,6	58,0	62,4	54,4	42,5

⁽¹⁾ Refrigerating capacities according to Standard ARI 710-86 for $T_o = -15\text{ °C}$, $T_k = 30\text{ °C}$ and $\Delta p = 0.07\text{ bar}$.

If different conditions, refer to correction factors in chapter 112 of CARLY technical catalogue.

⁽²⁾ Dehydratable refrigerant capacity according to Standard ARI 710-86.

⁽³⁾ Refrigerating capacities Q_n for $T_k = -10\text{ °C}$ and $T_o = -40\text{ °C}$

If different conditions, refer to correction factors in chapter 112 of CARLY technical catalogue.

Nota: the diameter of connections must not be inferior to the diameter of the main pipe.



Filter driers

→ DCY-P6 / 64 bar (928 psig)

■ Example of selection of a DCY-P6 filter drier

The sizing of a product implies that the buyer takes into account the conditions under which the product is going to be used (temperature - pressure - refrigerant - oil - external environment). The values proposed in the CARLY catalogue selection tables match specific test conditions.

In order to define a correct sizing, we suggest that you convert your operating data into data that match the CARLY selection tables.

- Installation operating with CO₂ under the following conditions⁽¹⁾ :
 - To = - 40 °C
 - Tk = - 10 °C
 - Q_o = 78 kW
 - 42 kg of refrigerant at 24 °C
- Which DCY-P6 filter drier to choose?

DCY-P6 selection

• DCY-P6 type selection and reading of selection table on page 1.12

- CO₂
- 42 kg refrigerant at 24 °C
- Q_o = 78 kW

Filter drier volume selection depends on the installation total refrigerant capacity. For a quantity of 42 kg of CO₂, selection should be done from the DCY-P6 300 product line. See dehydratable refrigerant capacity column.

Selection of the connection, hence of the filter drier, is performed by carrying the Q_o refrigerating capacity and the refrigerant over to the refrigerating capacity column.

Result: DCY-P6 305 S/MMS (connections to solder) or DCY-P6 305 (connections to screw)

If the Q_o value is between two CARLY filter drier types in the selection table, it is recommended to select the filter drier with the greater capacity.

CARLY references	Connections		CARLY references	Connections To solder ODF mm	Refrigerating capacity kW ⁽¹⁾					Dehydratable refrigerant capacity kg of refrigerant ⁽²⁾						
	To screw SAE inch	To solder ODF inch			R22 R1233zd	R134a R407C R410A R407F	R404A R507A R452A	R1234ze R513A R448A R449A R450A R455A	R744 CO ₂	R22 R450A R1233zd	R134a R1234ze	R407C R513A R1234ze	R404A R410A R448A R449A	R455A R455A	R744 CO ₂ ⁽³⁾	
					24 °C	52 °C	24 °C	52 °C	24 °C	52 °C	24 °C	52 °C	24 °C			
DCY-P6 164	1/2				41,5	40,0	43,0	34,8	46,5	40	34	38,1	32,4	35,7	30,3	24,3
DCY-P6 164 S		1/2	DCY-P6 164 MMS	12	41,5	40,0	43,0	34,8	46,5	40	34	38,1	32,4	35,7	30,3	24,3
DCY-P6 305	5/8				70,0	68,0	78,4	59,1	78,4	70	61	66,6	58,0	62,4	54,4	42,5
DCY-P6 305 S/MMS		5/8	DCY-P6 305 S/MMS	16	70,0	68,0	78,4	59,1	78,4	70	61	66,6	58,0	62,4	54,4	42,5

⁽¹⁾ Chapter "Abbreviations and units" (refer to chapter 113 of CARLY technical catalogue).

⁽²⁾ Dehydratable refrigerant capacity according to Standard ARI 710-86.



CTCY-EN - 1.11-6 / 09-2023

Filter driers

→ DCY-P6 / 64 bar (928 psig)

■ Technical features

CARLY references	Connections types ⁽¹⁾	Drawing Nb	Filtering surface cm ²	Volume of desiccation products cm ³	Dimensions		
					Ø1 mm	Ø2 mm	L mm
DCY-P6 053	1	1	52	82	50	55	126
DCY-P6 053 S	DCY-P6 053 MMS	2	52	82	50	55	110
DCY-P6 164	1	1	102	322	70	76	182
DCY-P6 164 S	DCY-P6 164 MMS	2	102	322	70	76	162
DCY-P6 305	1	1	102	582	70	76	262
DCY-P6 305 S/MMS	2	2	102	582	70	76	242

⁽¹⁾ Chapter "Connection features and drawings" (refer to chapter 114 of CARLY technical catalogue).

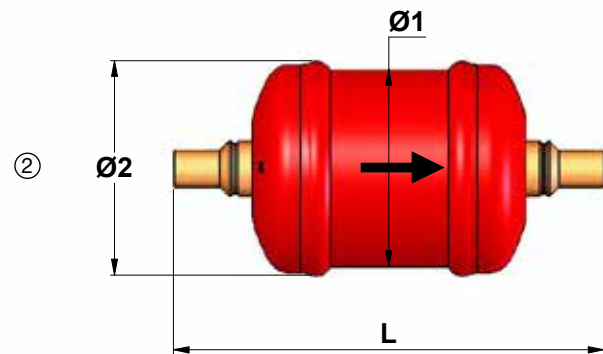
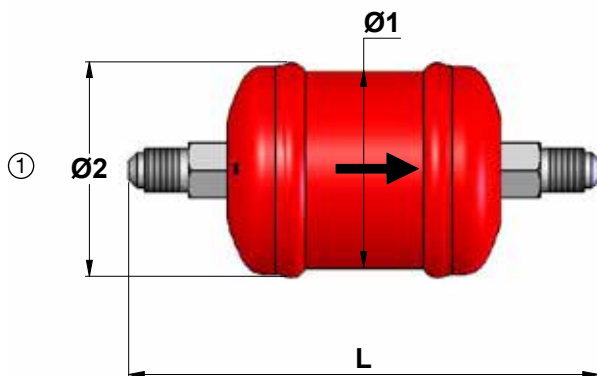

CARLY references	Volume V L	Maximal working pressure PS bar	Working pressure ⁽¹⁾ PS BT bar	Maximal working temperature TS maxi °C	Minimal working temperature TS mini °C	Working temperature ⁽¹⁾ TS BT °C	CE Category ⁽²⁾	
								DCY-P6 053
DCY-P6 053 S	DCY-P6 053 MMS	0,12	64	15	100	-40	-30	Art4§3
DCY-P6 164	0,42	64	15	100	-40	-30	Art4§3	
DCY-P6 164 S	DCY-P6 164 MMS	0,42	64	15	100	-40	-30	Art4§3
DCY-P6 305	0,68	64	15	100	-40	-30	Art4§3	
DCY-P6 305 S/MMS	0,68	64	15	100	-40	-30	Art4§3	

⁽¹⁾ The working pressure is limited to the PS BT value when working temperature is lower than or equal to TS BT value.

⁽²⁾ Classification by volume, according to PED 2014/68/EU (refer to Chapter 0 of CARLY technical catalogue).



Filter driers

→ DCY-P6 / 64 bar (928 psig)

■ Weights and packaging

CARLY references	Unit weight kg		Packaging number of pieces
	With packaging	Without packaging	
DCY-P6 053	0,33	0,30	1
DCY-P6 053 S & MMS	0,33	0,30	1
DCY-P6 164	1,04	1,00	1
DCY-P6 164 S& MMS	1,04	1,00	1
DCY-P6 305	1,57	1,50	1
DCY-P6 305 S/MMS	1,57	1,50	1