



## Cleaning filters for liquid and suction lines (temporary use)

### → NCY

#### ■ Applications

- Cleaning and decontamination of refrigerant circuits in refrigerating and air conditioning installations.
- Temporary uses:
  - new installations during start-up period for a very efficient protection of compressors against all types of dirt.
  - existing installations for an efficient cleaning of the refrigerant after compressor burnout.

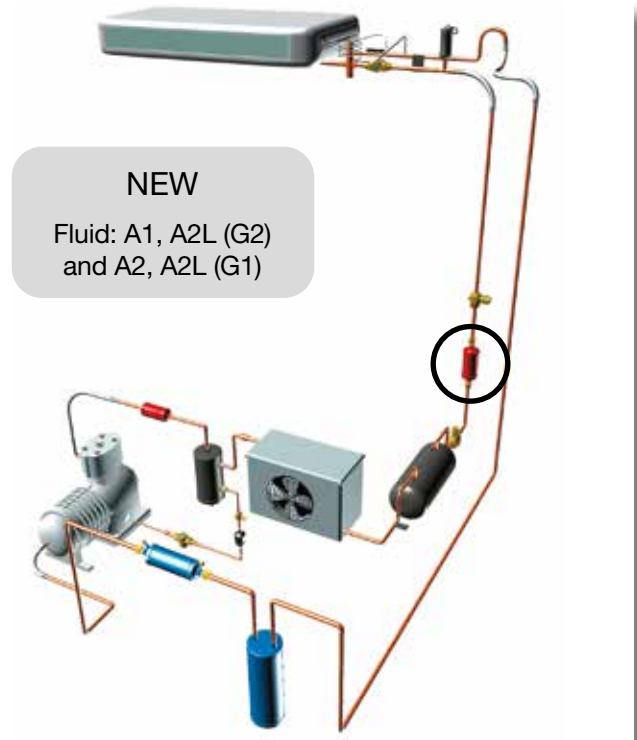

#### ■ Functional features

- Products are compatible with HCFCs, HFCs, HFOs, CO<sub>2</sub>, as well as with their associated oils and additives. Products are designed for use of non-hazardous refrigerants from group 2 of PED 2014/68/EU. To use CARLY components with fluids of the hydrocarbon group 1 – Propane R290, Butane R600, Isobutane R600a, Propylene R1270 – with HFOs and transcritical CO<sub>2</sub> and for a RANKINE organic cycle application, contact CARLY technical department.
- Product classification in CE categories is performed using the PED 2014/68/EU table, corresponding to a volume-based selection.
- Hermetically sealed outer steel enclosure with paint to ensure a high resistance to corrosion.
- Filtering at outlet preventing propagation within the circuit of particles bigger than 25 microns, with a very low pressure drop.
- No desorption, even at high temperatures.
- A dispenser located at the intake ensures optimal distribution and permanent treatment of the whole refrigerant, inside the cleaning filter driers.
- They integrate all the elements of the filter driers DCY, plus:
  - A decantation filter located at the intake to stop the flow of particles such as iron and copper oxides, carbon, foundry sand, etc.
  - Active charcoal to contain the waxes, the oily sludge, etc.
  - A permanent magnet located at the intake that traps the steel particles (except for models NCY 63 and 63 S/MMS).
- Several types of connections are possible on standard products:
  - To be screwed type SAE
  - To be brazed for tubes in inches (S)
  - To be brazed for tubes in millimeters (MMS).



#### Possible customization on demand:

- Specific connections (O-RING, ORFS, ...)

#### ■ CARLY advantages

- Maximal working pressure: 46 bar.
- Great efficiency for acid, wax binding and oily sludge neutralization at all temperatures, thanks to a fair distribution of chemical agents present in the filters: molecular sieves, activated alumina, active charcoal.
- Chemical agents in the form of free grain, for increased performance and elimination of the risk of polluting the circuit with solid particles, consecutive to drying core break-up.
- Very economical cleaning process with no loss of time, because the installation is still running during the operation.
- Environmental protection and savings of refrigerant, because using these cleaning filters allows re-use of the refrigerant after pollution control.
- Two access valves that allow filter pressure drop measurement, and define its level of saturation (except for models NCY 63 and 63 S/MMS).
- The copper-plated steel connections facilitate the brazing and allow using filler metals with a low silver percentage.



# Cleaning filters for liquid and suction lines (temporary use)

## → NCY

### ■ Warning

Before selecting or installing any component, please refer to the chapter 0 - **WARNING**.

### ■ General assembly precautions

The installation of a component in a refrigeration system by a skilled professional, requires some precautions:

- Some are specific to each component, and in this case, they are specified in the

**RECOMMENDATIONS SPECIFIC** part defined hereafter ;

- Other are general to all CARLY components, they are presented in the chapter 115 – **GENERAL ASSEMBLY PRECAUTIONS**.

- The recommendations relating to the CARLY components for the subcritical CO<sub>2</sub> applications are also developed in chapter 115 – **GENERAL ASSEMBLY PRECAUTIONS**.

### ■ Recommendations specific to the NCY Cleaning filter driers

- Cleaning filter driers are to be mounted on the suction line between the evaporator outlet and the compressor or in the liquid line just after the receiver.
- The refrigerant flow direction is indicated by an "IN" mark in the inlet shell of the filter drier and by an arrow on the filter tag. It must be necessarily respected.
- These filters are products intended for temporary use only; they should not be left permanently on the circuit.
- Closely monitor the pressure drop thanks to the access valves, in order to prevent shortage of the refrigerant vapour

required to cool the compressor engine. The replacement of the cleaning filters is imperative when the pressure drop measured in the filter is too large.

- After compressor burnout:
  - refer to the instructions given by the manufacturer, for circuit cleaning operations and compressor replacement
  - visually monitor the oil condition and acidity level with TESTOIL-MAS, TESTOIL-POE and TESTOIL-3P-CO<sub>2</sub> acidity tests (refer to chapter 91).
- The decontamination procedure of a refrigerating circuit, after compressor

burnout, using NCY cleaning filters, is identical to that for FNCY cleaning filters (description: refer to chapter 15).

- Make sure that the piping can support, without deformation, the weight of the cleaning filter; otherwise, plan the attachment of the cleaning filter with a clamp on a stable part of the installation.



## Cleaning filters for liquid and suction lines (temporary use)

CTCY-EN - 13.1-8 / 01-2023

### → NCY

#### ■ Selection table: Group 2 fluids (A1, A2L)

CARLY references	Connections		CARLY references	Connections To solder ODF mm	Refrigerating capacity kW <sup>(1)</sup>					Dehydratable refrigerant capacity kg of refrigerant <sup>(3)</sup>						
	To screw SAE inch	To solder ODF inch			R22 R407F R407C R404A R448A R449A	R134a R513A R450A R1234ze	R1233zd	R410A	R744 <sup>(2)</sup>	R22 R450A R134a R1233zd	R407F R452A R407C R513A R1234ze	R404A R507 R455A R410A R448A R449A	R744			
					inch	52 °C	24 °C	52 °C	24 °C	52 °C	24 °C					
NCY 63	3/8				1,5	1,4	0,2	2,2	1,5	15,0	14,5	14,3	13,8	13,4	12,9	9,1
NCY 63 S		3/8	NCY 63 MMS	10	1,5	1,4	0,2	2,2	1,5	15,0	14,5	14,3	13,8	13,4	12,9	9,1
NCY 73	3/8				4,3	3,9	0,6	6,3	4,3	40,0	34,0	38,1	32,4	35,7	30,3	24,3
NCY 73 S		3/8	NCY 73 MMS	10	4,3	3,9	0,6	6,3	4,3	40,0	34,0	38,1	32,4	35,7	30,3	24,3
NCY 74	1/2				5,7	5,2	0,8	8,4	5,7	40,0	34,0	38,1	32,4	35,7	30,3	24,3
NCY 74 S		1/2	NCY 74 MMS	12	5,7	5,2	0,8	8,4	5,7	40,0	34,0	38,1	32,4	35,7	30,3	24,3
NCY 75	5/8				14,4	13,1	2,0	21,2	14,2	70,0	61,0	66,6	58,0	62,4	54,4	42,5
NCY 75 S/MMS		5/8	NCY 75 S/MMS	16	14,4	13,1	2,0	21,2	14,2	70,0	61,0	66,6	58,0	62,4	54,4	42,5

<sup>(1)</sup> Refrigerating capacities according to Standard ARI 730-2001 for  $T_o = 4.4\text{ °C}$ ,  $T_k = 32\text{ °C}$  and  $\Delta p = 0.21\text{ bar}$ .  
If different conditions, refer to correction factors in chapter 112.

<sup>(2)</sup> Refrigerating capacities  $Q_n$  for  $T_k = -10\text{ °C}$  and  $T_o = -40\text{ °C}$   
If different conditions, refer to correction factors in chapter 112.

<sup>(3)</sup> Dehydratable refrigerant capacity according to Standard ARI 710-86.  
Nota: the diameter of connections must not be inferior to the diameter of the main pipe.

#### ■ Selection table: Group 1 fluids (A2, A2L)

CARLY references	Connections		CARLY references	Connections To solder ODF mm	Refrigerating capacity kW <sup>(1)</sup>						Dehydratable refrigerant capacity kg of refrigerant <sup>(3)</sup>			
	To solder ODF mm				R1234yf R152a	R32	R447A R452B	R454A R455A	R454B	R454C	R152a R32 R454B R447A R452B		R454A R455A R454C R1234yf	
											24 °C	52 °C	24 °C	52 °C
NCY 63 S	3/8		NCY 63 MMS	10	0,8	2,1	1,9	1,3	1,7	1,1	12,3	11,8	13,3	12,9

<sup>(1)</sup> Refrigerating capacities according to Standard ARI 730-2001 for  $T_o = 4.4\text{ °C}$ ,  $T_k = 32\text{ °C}$  and  $\Delta p = 0.21\text{ bar}$ .  
If different conditions, refer to correction factors in chapter 112.

<sup>(2)</sup> Refrigerating capacities  $Q_n$  for  $T_k = -10\text{ °C}$  and  $T_o = -40\text{ °C}$   
If different conditions, refer to correction factors in chapter 112.

<sup>(3)</sup> Dehydratable refrigerant capacity according to Standard ARI 710-86.  
Nota: the diameter of connections must not be inferior to the diameter of the main pipe.



CTCY-EN - 13.1-8 / 01-2023

# Cleaning filters for liquid and suction lines (temporary use)

## → NCY

### ■ Selection table (in a liquid line): Group 2 fluids (A1, A2L)

CARLY references	Connections		CARLY references	Connections To solder ODF mm	Refrigerating capacity kW <sup>(1)</sup>				Dehydratable refrigerant capacity kg of refrigerant <sup>(3)</sup>						
	To screw SAE inch	To solder ODF inch			R22 R1233zd	R134a R407C R410A R407F	R22 R407C R410A R407F R1233zd	R744 <sup>(2)</sup>	R22 R450A R134a R1233zd		R407F R452A R407C R513A R1234ze		R404A R507 R455A R410A R448A R449A		R744
									24 °C	52 °C	24 °C	52 °C	24 °C	52 °C	
NCY 63	3/8				25,2	21,9	17,0	24,5	6,5	5,5	6,2	5,2	5,8	4,9	3,9
NCY 63 S		3/8	NCY 63 MMS	10	25,2	21,9	17,0	24,5	6,5	5,5	6,2	5,2	5,8	4,9	3,9
NCY 73	3/8				25,7	22,7	18,0	25,0	6,5	5,5	6,2	5,2	5,8	4,9	10
NCY 73 S		3/8	NCY 73 MMS	10	25,7	22,7	18,0	25,0	6,5	5,5	6,2	5,2	5,8	4,9	10
NCY 74	1/2				43,6	38,0	32,0	43,0	9,5	9,0	9,0	8,6	8,5	8,0	10
NCY 74 S		1/2	NCY 74 MMS	12	43,6	38,0	32,0	43,0	9,5	9,0	9,0	8,6	8,5	8,0	10
NCY 75	5/8				73,5	64,4	51,0	72,0	9,5	9,0	9,0	8,6	8,5	8,0	18,5
NCY 75 S/MMS		5/8	NCY 75 S/MMS	16	73,5	64,4	51,0	72,0	9,5	9,0	9,0	8,6	8,5	8,0	18,5

<sup>(1)</sup> Refrigerating capacities according to Standard ARI 730-2001 for  $T_o = 4.4^\circ\text{C}$ ,  $T_k = 32^\circ\text{C}$  and  $\Delta p = 0.07$  bar.  
If different conditions, refer to correction factors in chapter 112.

<sup>(2)</sup> Refrigerating capacities  $Q_n$  for  $T_k = -10^\circ\text{C}$  and  $T_o = -40^\circ\text{C}$   
If different conditions, refer to correction factors in chapter 112.

<sup>(3)</sup> Dehydratable refrigerant capacity according to Standard ARI 710-86.  
Nota: the diameter of connections must not be inferior to the diameter of the main pipe.

### ■ Selection table (in a liquid line): Group 1 fluids (A2, A2L)

CARLY references	Connections		CARLY references	Connections To solder ODF mm	Refrigerating capacity kW <sup>(1)</sup>						Dehydratable refrigerant capacity kg of refrigerant <sup>(3)</sup>			
	To screw SAE inch	To solder ODF inch			R1234yf R152a	R32	R447A R452B	R454A R455A	R454B	R454C	R152a R32 R454B R447A R452B		R454A R455A R454C R1234yf	
											24 °C	52 °C	24 °C	52 °C
NCY 63 S	3/8		NCY 63 MMS	10	15,1	30,5	27,0	22,5	25,5	21,2	5,3	4,5	5,8	4,9

<sup>(1)</sup> Refrigerating capacities according to Standard ARI 730-2001 for  $T_o = 4.4^\circ\text{C}$ ,  $T_k = 32^\circ\text{C}$  and  $\Delta p = 0.07$  bar.  
If different conditions, refer to correction factors in chapter 112.

<sup>(2)</sup> Refrigerating capacities  $Q_n$  for  $T_k = -10^\circ\text{C}$  and  $T_o = -40^\circ\text{C}$   
If different conditions, refer to correction factors in chapter 112.

<sup>(3)</sup> Dehydratable refrigerant capacity according to Standard ARI 710-86.  
Nota: the diameter of connections must not be inferior to the diameter of the main pipe.



## Cleaning filters for liquid and suction lines (temporary use)

CTCY-EN - 13.1-8 / 01-2023

### → NCY

#### ■ Technical features

CARLY references	Connection types <sup>(1)</sup>	Drawing Nb	Filtering surface cm <sup>2</sup>	Volume desiccation products cm <sup>3</sup>	Dimensions mm		
					Ø1	Ø2	L
NCY 63	1	1	52	125,0	50	55	156
NCY 63 S    NCY 63 MMS	2	2	52	125,0	50	55	140
NCY 73	1	3	102	315,0	70	76	176
NCY 73 S    NCY 73 MMS	2	4	102	315,0	70	76	160
NCY 74	1	3	102	315,0	70	76	180
NCY 74 S    NCY 74 MMS	2	4	102	315,0	70	76	160
NCY 75	1	3	102	581,6	70	76	260
NCY 75 S/MMS	2	4	102	581,6	70	76	240

<sup>(1)</sup> Chapter «Connection features and drawings» (refer to chapter 114).

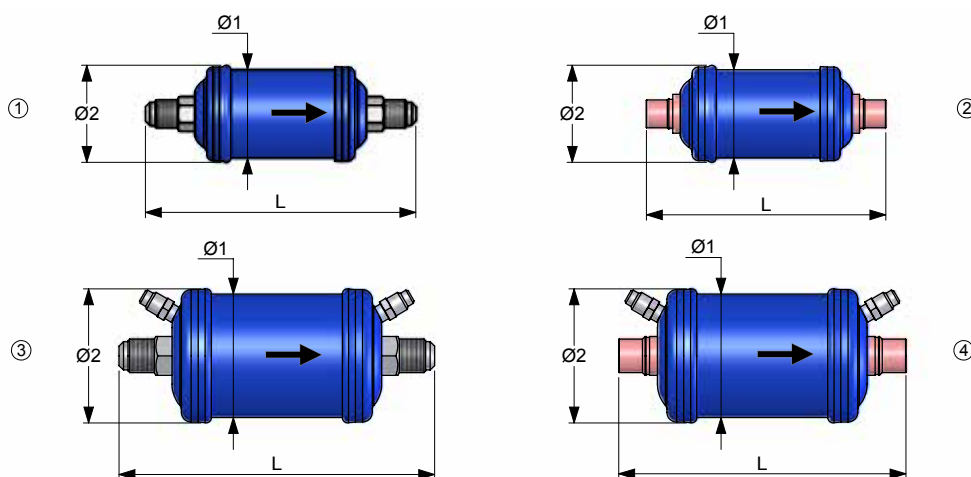

CARLY references	Volume V L	Max. working pressure				Working pressure <sup>(1)</sup> PS BT bar	Maximal working temperature TS maxi °C	Minimal working temperature TS mini °C	Working temperature <sup>(1)</sup> TS BT °C	CE Category <sup>(2)</sup>
		G2 (46bar)		G1 (46bar)						
		A1	A2L	A2	A2L					
NCY 63	0,17	X	X			15	100	-40	-30	Art4§3
NCY 63 S    NCY 63 MMS	0,17	X	X	X	X	15	100	-40	-30	Art4§3
NCY 73	0,39	X	X			15	100	-40	-30	Art4§3
NCY 73 S    NCY 73 MMS	0,39	X	X			15	100	-40	-30	Art4§3
NCY 74	0,41	X	X			15	100	-40	-30	Art4§3
NCY 74 S    NCY 74 MMS	0,41	X	X			15	100	-40	-30	Art4§3
NCY 75	0,41	X	X			15	100	-40	-30	Art4§3
NCY 75 S/MMS	0,41	X	X			15	100	-40	-30	Art4§3

<sup>(1)</sup> The working pressure is limited to the PS BT value when working temperature is lower than or equal to TS BT value.

<sup>(2)</sup> Classification by volume, according to PED 2014/68/EU (refer to chapter 0).



# Cleaning filters for liquid and suction lines (temporary use)

## → NCY

### ■ Weights and packaging

CARLY references	Unit weight kg		Packaging number of pieces
	With packaging	Without packaging	
NCY 63	0,43	0,40	1
NCY 63 S & MMS	0,43	0,40	1
NCY 73	0,99	0,95	1
NCY 73 S & MMS	0,99	0,95	1
NCY 74	1,04	1,00	1
NCY 74 S & MMS	1,04	1,00	1
NCY 75	1,54	1,50	1
NCY 75 S/MMS	1,54	1,50	1