



Oil separators

→ TURBOIL® (welded) / TURBOIL-F® (flanged)

■ Applications

- Separation and recovery of the oil carried by the refrigerant in vapour phase at compressor outlet of refrigerating and air conditioning installations.
- The TURBOIL® oil separators limit the amount of oil within the circuit, thus allowing increasing the performances of the heat exchangers and prevent abnormal wear, even the breakage of compressors by lack of oil.
- They must be used in applications where the return of oil through the suction is not guaranteed: facilities with long pipes, oil traps, with evaporation temperatures lower than -5°C, with compressors in parallel, or with variable speed, for systems with multiple compressor stages in cascade, Flood, Booster...
- They ensure a regulated oil return to the compressor crankcases and participate by their position on the circuit, in the reduction of the vibrations generated by the compressors and sound level of the discharge gas.

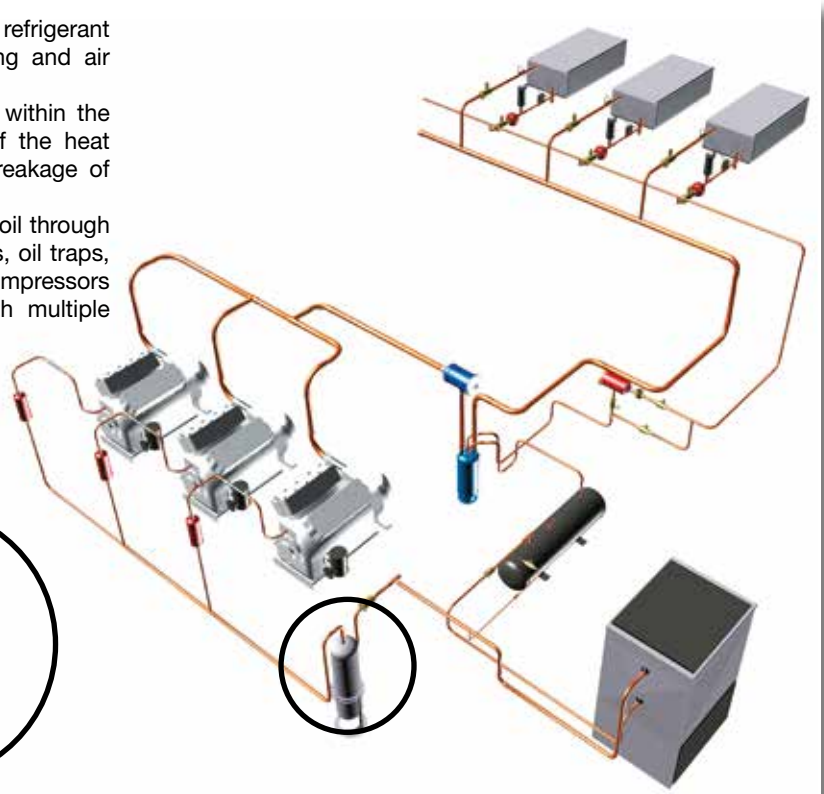

■ Functional features

- Products are compatible with HCFCs, HFCs, HFOs, CO₂, as well as with their associated oils and additives. Products are designed for use of non-hazardous refrigerants from group 2 of PED 2014/68/EU. To use CARLY components with fluids of the hydrocarbon group 1, contact CARLY technical department.
- Product classification in CE categories is performed using the PED 2014/68/EU table, corresponding to a volume based selection.
- Hermetically sealed outer steel enclosure with paint to ensure a high resistance to corrosion.
- Two models are offered:
 - a welded version: TURBOIL®; these models have built-in fastening means
 - a flanged version: TURBOIL-F®, allowing cleaning the float/needle oil return system; these models are not fitted with built-in fastening, means: appropriate support legs are available as an option.
- The automatic regulation of the oil return directly to the compressor crankcases or through an oil receiver is ensured by a robust, accurate and protected unit (float, valve, and needle)
- Several maximum operating differential pressure: $\Delta P_f = \text{discharge pressure} - \text{pressure of oil return circuit}$.



Possible customization on demand:

- Separator with oil return by capillary (onboard refrigeration)
- Centrifugal separator

■ CARLY advantages

- Maximum working pressure up to 46 bar.
- Reliability and efficiency of the TURBOIL® oil separators are ensured thanks to a CARLY patented process, simultaneously associating several oil separation techniques:
 - centrifugation by helical motion generated by one or several spirals
 - coalescence thanks to the needled material of these spirals
 - sudden modification of speed by increase of the flow area located at the separator's inlet
 - sudden change of direction: inlet of the mixture by the top, outlet of the refrigerant from the higher lateral part and outlet of the oil from the lower part.
- Low pressure drop compare to a separator using coalescent cores
- Do not need specific maintenance operations, because there is no cores to be replace periodically.
- The presence of an internal baffle eliminates a new risk of the oil being carried by the refrigerant.
- Presence of a 1/4" NPT drain plug in the lower part from model TURBOIL® F-7011 S/MMS to model TURBOIL 9017 S/MMS and from model TURBOIL-F 2505 S/MMS to model TURBOIL-F 30025 S/MMS.



CTCY-EN - 41.1-9 / 09-2023

Oil separators

→ TURBOIL® (welded) / TURBOIL-F® (flanged)

■ Warning

Before selecting or installing any component, please refer to the chapter 0 - **WARNING**.

■ General assembly precautions

The installation of a component in a refrigeration system by a skilled professional, requires some precautions:

- Some are specific to each component, and in this case, they are specified in the

RECOMMENDATIONS SPECIFIC part defined hereafter ;

- Other are general to all CARLY components, they are presented in the chapter 115 – **GENERAL ASSEMBLY PRECAUTIONS**.

- The recommendations relating to the CARLY components for the subcritical CO₂ applications are also developed in chapter 115 – **GENERAL ASSEMBLY PRECAUTIONS**.

■ Recommendations specific to the oil separators TURBOIL

- To select the TURBOIL® oil separators, it is necessary to refer to the selection tables in the following pages, taking into account:
 - the refrigerating capacity
 - the type of refrigerant used
 - the evaporation and condensation temperatures.
 - the maximum operating differential pressure: ΔP_f
- Oil separators should be installed vertically on the discharge line, as close as possible to the compressor.
- Refrigerant flow direction with inlet from the top is imperative and identified on the upper cover plate with the letters "IN".
- Connection diameter of the oil separators should be higher than or equal to the diameter of the discharge line.
- In the case of a multi-compressor installation mounted in parallel, it is recommended to use one oil separator by compressor, in order to keep an optimal efficiency at all operating rates; otherwise, the separator should be selected based on the sum of each compressor's maximum capacity.
- The oil separation performances will depend directly on the flow rate of the oil/refrigerant mixture at the inlet of the separators.
- The oil return connection is done either at the filling plug on the compressor crankcase, or in the case of multi-compressor installations, at the oil receiver.
- In order to prevent all risks of refrigerant condensation, it is recommended to not install the oil separators in the air flow produced by the fans; in a cold environment, it may be necessary to provide for the installation of an heat insulation or a heating element around the separators.
- Before connecting the oil separator, it is necessary to introduce, by the higher

connection, an oil load corresponding to the load in litre indicated in the oil separator technical features tables. Use the same oil as the compressor.

- In case of implantation of a TURBOIL® oil separator after installation commissioning, it is necessary to monitor the oil level in the compressor crankcase, in order to collect a possible oil surplus caused by a return of the lubricant accumulated in the refrigerating circuit.
- An efficient oil return system design requires that all the components (TURBOIL®, HCYR, HCYCT, HCYF, LEVOIL, HYDROIL and HCYVP) are correctly selected according to

the installation's refrigerating capacity and operating rates.

- The efficiency of the oil separation is never 100 %, especially with variable operating regimes. The implementation of an oil separator does not exempt to avoid any trap oil and slopes in the direction of the fluid during the design and the construction of the pipes of the unit.
- A check valve can be installed on the pipe at the gas outlet of the oil separator, in order to avoid any return of liquid refrigerant from the condenser.

Oil / refrigerant mixture feed

CARLY patented TURBOIL® oil separation system ensuring the best oil/refrigerant separation rates thanks to an original design: change of speed, change of direction, centrifugation and coalescence phenomenon are ensured simultaneously

Carbon steel pin to prevent twisting risks

Reinforced retaining bracket

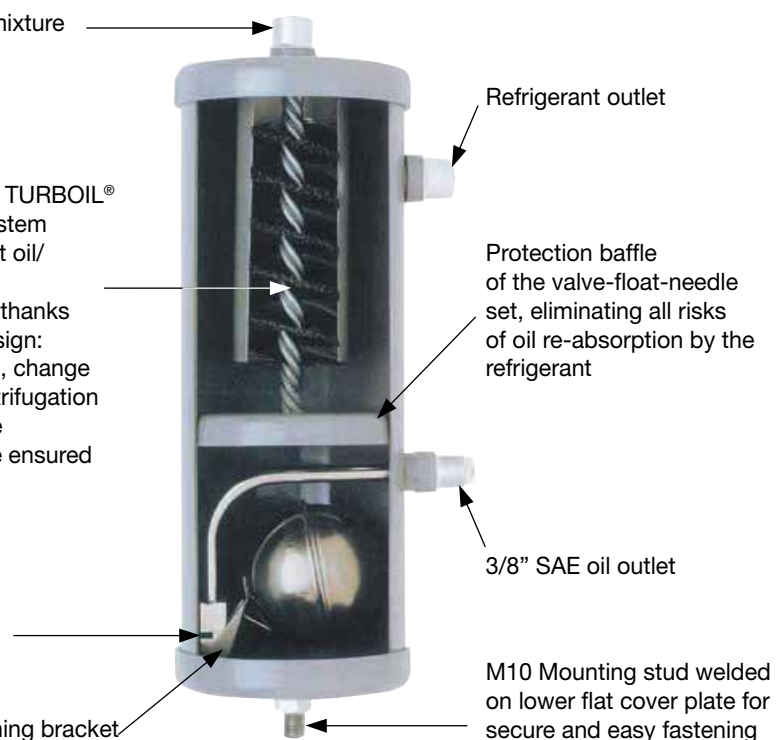



Oil separators

→ TURBOIL® (welded) / TURBOIL-F® (flanged)

■ Example of selection

The sizing of a product implies for the buyer to take into account the conditions under which the product will be used (temperature - pressure - refrigerant - oil - external environment). The values of the selection tables proposed in the CARLY catalogue match accurate test conditions.

We recommend that you convert your operating data into data matching the CARLY selection table so that you can perform a rigorous and correct sizing.

For a condensation temperature different from 38 °C, it is recommended to convert the installation's refrigerating capacity using the following formula:

$$Q_o^{Tk\ 38} = Q_o^{Tk\ x} / \{ (Tkx - 38) \times 0,0143 + 1 \}$$

- ⁽¹⁾ $Q_o^{Tk\ x}$ = installation's refrigerating capacity at initial condensation temperature (kW)
- $Tk\ x$ = initial condensation temperature (°C)
- $Q_o^{Tk\ 38}$ = installation's refrigerating capacity at a condensation temperature of 38 °C (kW)

SELECTION OF A TURBOIL® MODEL CORRESPONDING TO THE CORRECTED REFRIGERATING CAPACITY.

• Installation operating with R404A under the following conditions:

- $T_o = -10\ ^\circ C$
- $Tk = 30\ ^\circ C$
- $Q_o^{Tk\ x} = 75\ kW$
- Compressor discharge = 1" 5/8

• Which TURBOIL® to choose?

Application of the formula

$$Q_o^{Tk\ 38} = Q_o^{Tk\ x} / \{ (Tkx - 38) \times 0,0143 + 1 \}$$

$$75 / \{ (30 - 38) \times 0.0143 + 1 \} = 85\ kW$$

Refer to the selection table page 41.4

**Result:
TURBOIL 8013 S**

Make sure that the TURBOIL® oil separator connection diameter is at least equal to the compressor discharge line diameter. The selected oil separator has a connection diameter identical to the piping diameter.



Make sure that the actual differential pressure of operation ΔPf is lower than that of the selected separator (see «technical features» table).

⁽¹⁾ Chapter «Abbreviations and units» (refer to chapter 113).



Oil separators

→ TURBOIL[®] (welded)

■ Selection table

CARLY references	Connections To solder ODF inch	CARLY references	Connections To solder ODF mm	Refrigerating capacity kW ⁽¹⁾												
				R22 R407C R507 R404A R452A R449A R448A			R134a R513a R450A R1234ze			R1233zd			R407F R410A			R744 ⁽²⁾
				-40 °C	-10 °C	+5 °C	-40 °C	-10 °C	+5 °C	-40 °C	-10 °C	+5 °C	-40 °C	-10 °C	+5 °C	-40 °C
TURBOIL 1503 S	3/8	TURBOIL 1503 MMS	10	5,0	6,0	7,0	3,5	4,5	5,0	1,0	1,1	1,3	6,0	7,2	8,4	10,0
TURBOIL 1504 S	1/2	TURBOIL 1504 MMS	12	6,0	7,0	8,0	4,0	5,0	5,5	1,1	1,3	1,5	7,2	8,4	9,6	12,0
TURBOIL 2505 S/MMS	5/8	TURBOIL 2505 S/MMS	16	17,0	22,0	25,0	12,0	15,0	17,0	3,2	4,2	4,8	20,4	26,4	30,0	27,0
TURBOIL 3006 S	3/4	TURBOIL 3006 MMS	18	22,0	27,0	30,0	16,0	21,0	23,0	4,2	5,1	5,7	26,4	32,4	36,0	42,0
TURBOIL 3007 S	7/8	TURBOIL 3007 MMS	22	26,0	30,0	32,0	18,0	23,0	25,0	4,9	5,7	6,1	31,2	36,0	38,4	54,0
TURBOIL 3009 S	1 1/8	TURBOIL 3009 MMS	28	29,0	36,0	40,0	19,0	25,0	28,0	5,5	6,8	7,6	34,8	43,2	48,0	95,0
TURBOIL 3011 S/MMS	1 3/8	TURBOIL 3011 S/MMS	35	32,0	40,0	47,0	21,0	27,0	31,0	6,1	7,6	8,9	38,4	48,0	56,4	124,0
TURBOIL 4007 S	7/8	TURBOIL 4007 MMS	22	32,0	40,0	44,0	26,0	34,0	38,0	6,1	7,6	8,4	38,4	48,0	52,8	95,0
TURBOIL 6009 S	1 1/8	TURBOIL 6009 MMS	28	42,0	54,0	60,0	34,0	37,0	42,0	8,0	10,3	11,4	50,4	64,8	72,0	95,0
TURBOIL 6011 S/MMS	1 3/8	TURBOIL 6011 S/MMS	35	48,0	60,0	70,0	38,0	46,0	50,0	9,1	11,4	13,3	57,6	72,0	84,0	149,0
TURBOIL 7011 S/MMS	1 3/8	TURBOIL 7011 S/MMS	35	48,0	60,0	70,0	38,0	46,0	50,0	9,1	11,4	13,3	57,6	72,0	84,0	149,0
TURBOIL 8013 S	1 5/8	TURBOIL 8013 MMS	42	65,0	85,0	94,0	45,0	60,0	70,0	12,4	16,2	17,9	78,0	102,0	112,8	210,0
TURBOIL 9017 S/MMS	2 1/8	TURBOIL 9017 S/MMS	54	87,0	105,0	120,0	58,0	70,0	80,0	16,5	20,0	22,8	104,4	126,0	144,0	288,0

⁽¹⁾ The indicated refrigerating capacities take into account a condensation temperature of + 38 °C, a 5 °C sub-refrigeration, 5° overheat and an aspirated gas temperature of + 18 °C.

⁽²⁾ Refrigerating capacity Q_n for T_k = + 0 °C

For T_k = - 10 °C Q₀ = Q_n - 22 %,

For T_k = - 20 °C Q₀ = Q_n - 41 %.

Refer to selection example page 41.3.



Oil separators

→ TURBOIL® (welded)

■ Technical features

CARLY references	Connections types (1)	Drawing No	Dimensions mm							
			Ø1	Ø2	L	E1	E2	E3	E4	
TURBOIL 1503 S	TURBOIL 1503 MMS	2	1	101,6	109,0	283	80	71	175	84
TURBOIL 1504 S	TURBOIL 1504 MMS	2	1	101,6	109,0	283	80	71	175	84
TURBOIL 2505 S/MMS		2	1	101,6	109,0	305	82	73	197	84
TURBOIL 3006 S	TURBOIL 3006 MMS	2	1	101,6	109,0	308	85	76	200	84
TURBOIL 3007 S/MMS		2	1	101,6	109,0	358	97	83	250	84
TURBOIL 3009 S	TURBOIL 3009 MMS	3	1	101,6	109,0	390	107	80	282	84
TURBOIL 3011 S/MMS		3	1	101,6	109,0	487	116	90	379	84
TURBOIL 6009 S	TURBOIL 6009 MMS	3	1	101,6	109,0	434	107	80	327	84
TURBOIL 6011 S/MMS		3	1	101,6	109,0	549	116	90	441	84
TURBOIL 7011 S/MMS		3	2	152,4	156,0	419	149	114	249	109
TURBOIL 8013 S	TURBOIL 8013 MMS	3	2	152,4	156,0	498	149	114	329	109
TURBOIL 9017 S/MMS		3	2	152,4	156,0	512	162	127	342	109

(1) Chapter «Connection features and drawings» (refer to chapter 114).

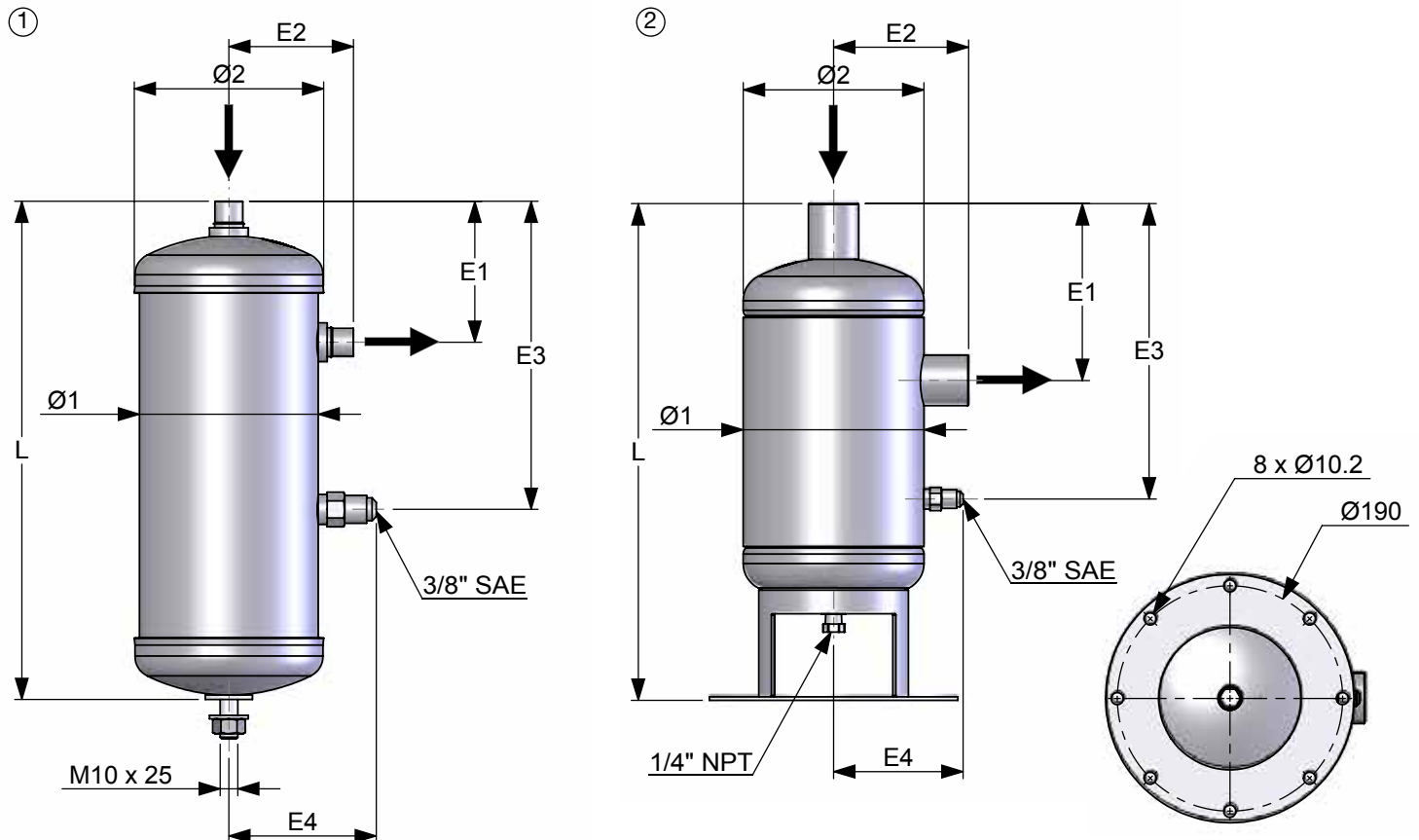



Oil separators

→ TURBOIL® (welded)

■ Technical features

CARLY references		Volume	Oil volume	Maximal working pressure	Working pressure ⁽¹⁾	Diferencial pressure ⁽³⁾	Maximal working temperature	Minimal working temperature	Working temperature ⁽¹⁾	CE Category ⁽²⁾
		V L	V L	PS bar	PS BT bar	ΔPf bar	TS maxi °C	TS mini °C	TS BT °C	
TURBOIL 1503 S	TURBOIL 1503 MMS	1,77	0,30	46	15	29	120	-40	-30	I
TURBOIL 1504 S	TURBOIL 1504 MMS	1,77	0,30	46	15	29	120	-40	-30	I
TURBOIL 2505 S/MMS		1,91	0,30	46	15	29	120	-40	-30	I
TURBOIL 3006 S	TURBOIL 3006 MMS	1,92	0,30	46	15	29	120	-40	-30	I
TURBOIL 3007 S/MMS		2,23	0,30	46	15	29	120	-40	-30	I
TURBOIL 3009 S	TURBOIL 3009 MMS	2,43	0,30	46	15	29	120	-40	-30	I
TURBOIL 3011 S/MMS		3,08	0,30	46	15	29	120	-40	-30	I
TURBOIL 6009 S	TURBOIL 6009 MMS	2,75	0,30	46	15	29	120	-40	-30	I
TURBOIL 6011 S/MMS		3,52	0,30	46	15	29	120	-40	-30	I
TURBOIL 7011 S/MMS		4,42	1,00	46	15	29	120	-40	-30	I
TURBOIL 8013 S	TURBOIL 8013 MMS	5,77	1,00	46	15	19	120	-40	-30	II
TURBOIL 9017 S/MMS		5,85	1,00	46	15	19	120	-40	-30	II

⁽¹⁾ The working pressure is limited to the PS BT value when working temperature is lower than or equal to TS BT value.

⁽²⁾ Classification by volume, according to PED 2014/68/EU (refer to chapter 0).

⁽³⁾ Maximum operating differential pressure ΔPf = Discharge pressure - oil return circuit pressure.



Oil separators

→ TURBOIL-F® (flanged)

■ Selection table

CARLY references	Connections To solder ODF pouce	CARLY references	Connections To solder ODF mm	Refrigerating capacity kW ⁽¹⁾												
				R22 R407C R507 R404A R452A R449A R448A			R134a R513a R450A R1234ze			R1233zd			R407F R410A			R744 ⁽²⁾
				-40 °C	-10 °C	+5 °C	-40 °C	-10 °C	+5 °C	-40 °C	-10 °C	+5 °C	-40 °C	-10 °C	+5 °C	-40 °C
TURBOIL-F 2505 S/MMS	5/8	TURBOIL-F 2505 S/MMS	16	17,0	22,0	25,0	12,0	15,0	17,0	2,4	3,0	3,4	20,4	26,4	30,0	27,0
TURBOIL-F 3007 S/MMS	7/8	TURBOIL-F 3007 S/MMS	22	25,0	30,0	32,0	18,0	23,0	25,0	3,6	4,6	5,0	30,0	36,0	38,4	54,0
TURBOIL-F 3009 S	1 1/8	TURBOIL-F 3009 MMS	28	29,0	36,0	40,0	19,0	25,0	28,0	3,8	5,0	5,6	34,8	43,2	48,0	95,0
TURBOIL-F 3011 S/MMS	1 3/8	TURBOIL-F 3011 S/MMS	35	32,0	40,0	47,0	21,0	27,0	31,0	4,2	5,4	6,2	38,4	48,0	56,4	124,0
TURBOIL-F 7011 S/MMS	1 3/8	TURBOIL-F 7011 S/MMS	35	48,0	60,0	70,0	38,0	46,0	50,0	7,6	9,2	10,0	57,6	72,0	84,0	149,0
TURBOIL-F 8013 S	1 5/8	TURBOIL-F 8013 MMS	42	65,0	85,0	94,0	45,0	60,0	70,0	9,0	12,0	14,0	78,0	102,0	112,8	210,0
TURBOIL-F 9017 S/MMS	2 1/8	TURBOIL-F 9017 S/MMS	54	87,0	105,0	120,0	58,0	70,0	80,0	11,6	14,0	16,0	104,4	126,0	144,0	288,0
TURBOIL-F 15013 S	1 5/8	TURBOIL-F 15013 MMS	42	105,0	130,0	148,0	78,0	96,0	109,0	15,6	19,2	21,8	126,0	156,0	177,6	327,5
TURBOIL-F 15017 S/MMS	2 1/8	TURBOIL-F 15017 S/MMS	54	125,0	154,0	175,0	91,0	112,0	127,0	18,2	22,4	25,4	150,0	184,8	210,0	367,0
TURBOIL-F 15021 S	2 5/8	TURBOIL-F 15021 MMS	67	142,0	175,0	200,0	104,0	128,0	146,0	20,8	25,6	29,2	170,4	210,0	240,0	565,0
TURBOIL-F 30025 S	3 1/8	TURBOIL-F 30025 MMS	80	220,1	269,8	305,3	161,9	198,8	225,8	32,4	39,8	45,2	264,1	323,8	366,4	643,0

⁽¹⁾ The indicated refrigerating capacities take into account a condensation temperature of + 38 °C, a 5 °C sub-refrigeration, 5° overheat and an aspirated gas temperature of + 18 °C.

⁽²⁾ Refrigerating capacity Qn for Tk = + 0 °C
 For Tk = - 10 °C Qo = Qn - 22 %,
 For Tk = - 20 °C Q0 = Qn - 41 %.

Refer to selection example page 41.3.

■ Float set internal cleaning or replacement procedure

- 1 • Isolate the **TURBOIL-F®** (or the **TURBOIL-RF®**)
- 2 • Purge the isolated circuit until atmospheric pressure is reached in the oil separator.
- 3 • Empty the oil present in the separator, using the 1/4" NPT drain plug located in the lower part of the **TURBOIL-F®**.
- 4 • Remove the bolts and remove the lower part of the **TURBOIL-F®**.
- 5 • Proceed to the cleaning or replacement, if necessary, of this lower part of the separator.
- 6 • Replace systematically the fastening gasket on the lower part of the separator (gasket references on page 41.10) (To select the right reference of the gasket, refer to paragraph spare parts, at the end of the chapter).
- 7 • Put back the lower part of the separator, uniformly and progressively tightening the fastening bolts. (refer to chapter 115 - GENERAL MOUNTING PRECAUTIONS - Criss-cross tightening).

 The recommended tightening torques are:
 → 30 N.m for TURBOIL-F 2505 S/MMS to 3011 S/MMS
 → 55 N.m for TURBOIL-F 7011 S/MMS to 9017 S/MMS
 → 30 N.m for TURBOIL-F 15013 S/MMS to 30025 S/MMS
- 8 • Screw back the 1/4" NPT drain plug on the lower part of the separator and make sure it is properly sealed.
- 9 • Evacuate the system and check the tightness of the installation before loading the separator with oil and putting back under pressure.



Oil separators

→ TURBOIL-F[®] (flanged)

■ Technical features

CARLY references	Connections types ⁽¹⁾	Drawing N°	Dimensions mm											
			Ø1	Ø2	Ø3	L1	L2	E1	E2	E3	E4	E5	E6	
TURBOIL-F 2505 S/MMS	2	1	101,6	109	140	303	441	82	73	111	204	222	35	
TURBOIL-F 3007 S/MMS	2	1	101,6	109	140	355	494	102	83	111	204	222	35	
TURBOIL-F 3009 S	TURBOIL-F 3009 MMS	3	1	101,6	109	140	387	526	107	88	111	204	222	35
TURBOIL-F 3011 S/MMS		3	1	101,6	109	140	485	623	116	90	111	204	222	35
TURBOIL-F 7011 S/MMS		3	1	152,4	156	200	395	523	148	114	104	258	276	40
TURBOIL-F 8013 S	TURBOIL-F 8013 MMS	3	1	152,4	156	200	428	555	148	114	104	258	276	40
TURBOIL-F 9017 S/MMS		3	1	152,4	156	200	441	569	161	127	104	258	276	40
TURBOIL-F 15013 S	TURBOIL-F 15013 MMS	3	2	219,1	224	150	492	821	174	149	305	126	249	35
TURBOIL-F 15017 S/MMS		3	2	219,1	224	150	550	879	195	171	305	126	249	35
TURBOIL-F 15021 S	TURBOIL-F 15021 MMS	3	2	219,1	224	150	565	894	215	184	305	126	249	35
TURBOIL-F 30025 S	TURBOIL-F 30025 MMS	3	2	219,1	224	150	577	906	234	185	305	126	249	35

⁽¹⁾ Chapter «Connection features and drawings» (refer to chapter 114).

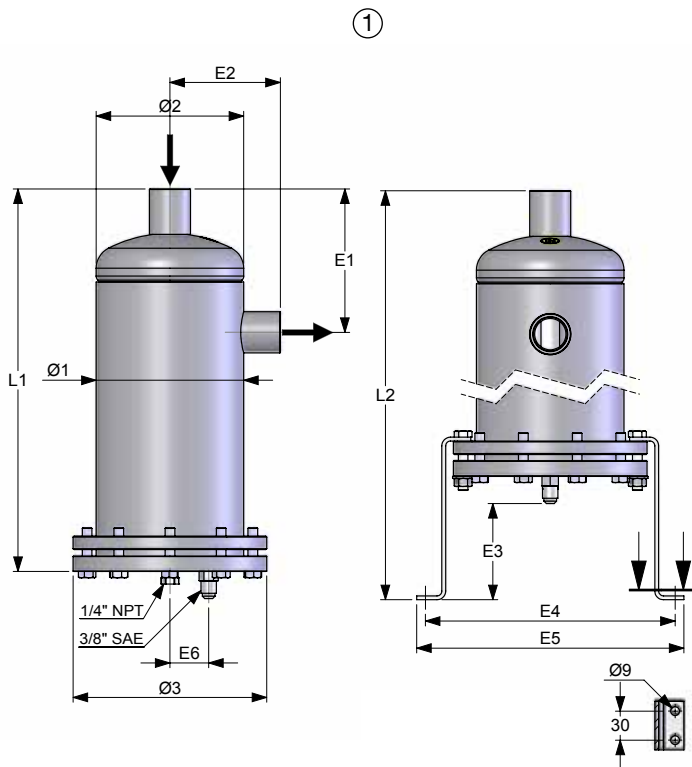

1 set of 2 supporting feet
on option
ref. CARLY: CY 37100260

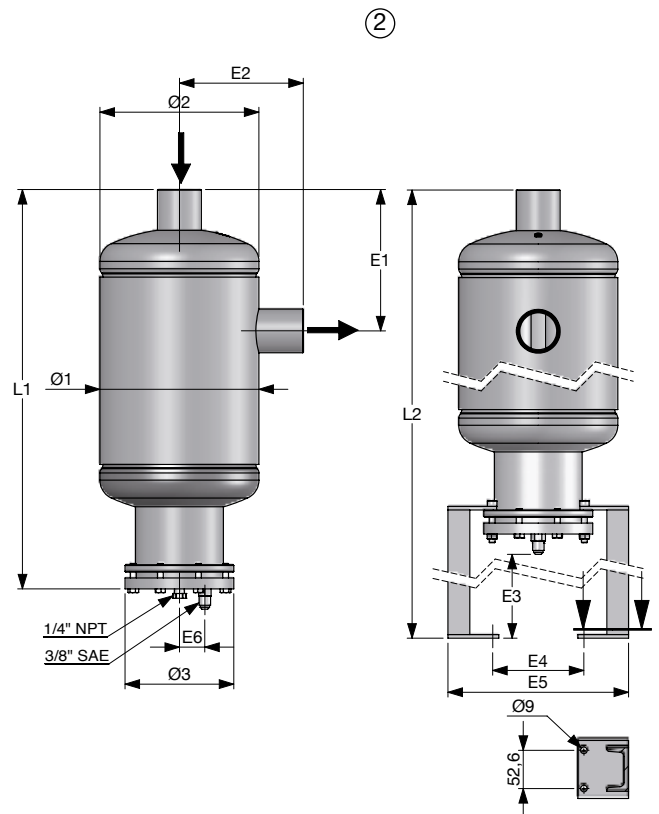

1 set of 2 supporting feet
on option
ref. CARLY: CY 38600220



Oil separators

➔ TURBOIL-F[®] (flanged)

■ Technical features

CARLY references	Volume	Oil volume	Maximal working pressure	Working pressure (1)	Diferencial pressure (3)	Maximal working temperature	Minimal working temperature	Working temperature (1)	CE Category (2)	
	V L	V L	PS bar	PS BT bar	ΔPf bar	TS maxi °C	TS mini °C	TS BT °C		
TURBOIL-F 2505 S/MMS	2,29	0,3	46	15	29	120	-40	-30	I	
TURBOIL-F 3007 S/MMS	2,62	0,3	46	15	29	120	-40	-30	I	
TURBOIL-F 3009 S	TURBOIL-F 3009 MMS	2,82	0,3	46	15	29	120	-40	-30	I
TURBOIL-F 3011 S/MMS		3,56	0,3	46	15	29	120	-40	-30	I
TURBOIL-F 7011 S/MMS		5,00	1,0	33	15	29	120	-40	-30	I
TURBOIL-F 8013 S	TURBOIL-F 8013 MMS	6,00	1,0	33	15	29	120	-40	-30	I
TURBOIL-F 9017 S/MMS		6,00	1,0	33	15	29	120	-40	-30	I
TURBOIL-F 15013 S	TURBOIL-F 15013 MMS	11,50	0,4	45	15	29	120	-40	-30	II
TURBOIL-F 15017 S/MMS		13,20	0,4	45	15	29	120	-40	-30	II
TURBOIL-F 15021 S	TURBOIL-F 15021 MMS	13,40	0,4	45	15	19	120	-40	-30	II
TURBOIL-F 30025 S	TURBOIL-F 30025 MMS	13,50	0,4	45	15	19	120	-40	-30	II

(1) The working pressure is limited to the PS BT value when working temperature is lower than or equal to TS BT value.

(2) Classification by volume, according to PED 2014/68/EU (refer to chapter 0).

(3) Maximum operating differential pressure $\Delta Pf = \text{Discharge pressure} - \text{oil return circuit pressure}$



Oil separators

→ TURBOIL-F® (flanged)

■ Spare parts

CARLY references	Part Nb	Description	TURBOIL-F® Types	Quantity
CY 37100250	1	1 set of 2 supporting feet	2505 S/MMS to 3011 S/MMS (Before 2010)	1
CY 37100260	1	1 set of 2 supporting feet	2505 S/MMS to 9017 S/MMS	1
CY 37100300	1	1 set of 2 supporting feet	7011 S/MMS to 9017 S/MMS (Before 2010)	1
CY 38600220	1	1 set of 2 supporting feet	15013 S/MMS to 30025 S/MMS	1
CY 15555301	2	Flat gasket for flange closure (blue)	2505 S/MMS to 3011 S/MMS	1
CY 15555304	2	Flat gasket for flange closure (blue)	7011 S/MMS to 9017 S/MMS	1
CY 15555303	2	Flat gasket for flange closure (blue)	15013 S/MMS to 30025 S/MMS	1
CY 19900420	3	Set of 8 screws for flange closure	15013 S/MMS to 30025 S/MMS	1
CY 19900425	3	Set of 6 screws for flange closure	2505 S/MMS to 3011 S/MMS	1
CY 19900520	3	Set of 10 screws for flange closure	7011 S/MMS to 9017 S/MMS	1
CY 10810010	4	1/4" NPT drain plug	2505 S/MMS to 3011 S/MMS 7011 S/MMS to 30025 S/MMS	1
CY 33402000	5	Lower part of separator with gasket and float set	2505 S/MMS to 3011 S/MMS (Before 2010)	1
CY 33403000	5	Lower part of separator with gasket and float set	7011 S/MMS to 9017 S/MMS (Before 2010)	1
CY 33800516	5	Flange with gasket and float set $\Delta P_f = 29$ bar	2505 S/MMS to 3011 S/MMS	1
CY 33801706	5	Flange with gasket and float set $\Delta P_f = 29$ bar	7011 S/MMS to 9017 S/MMS	1
CY 33800456	5	Flange with gasket and float set $\Delta P_f = 29$ bar	15013 S/MMS to 15017 S/MMS	1
CY 33303450	5	Flange with gasket and float set $\Delta P_f = 19$ bar	15021 S/MMS to 30025 S/MMS	1

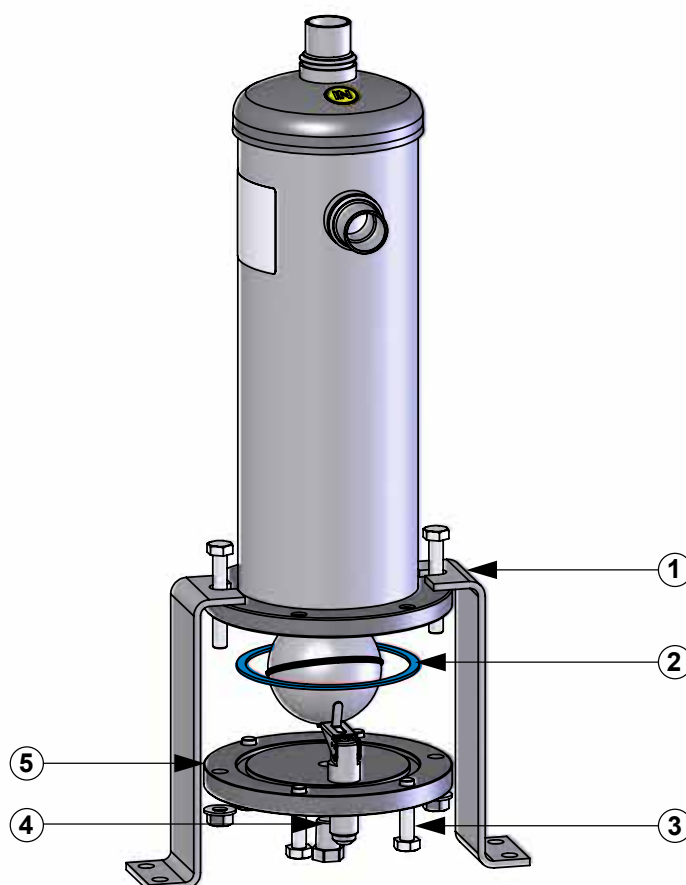



Oil separators

➔ TURBOIL® (welded) / TURBOIL-F® (flanged)

■ Weights and packaging

CARLY references	Unit weight kg		Packaging number of pieces
	With packaging	Without packaging	
TURBOIL 1503 S & MMS	2,90	2,65	1
TURBOIL 1504 S & MMS	3,35	3,10	1
TURBOIL 2505 S/MMS	3,55	3,25	1
TURBOIL 3006 S & MMS	3,75	3,45	1
TURBOIL 3007 S/MMS	4,20	3,90	1
TURBOIL 3009 S & MMS	4,25	3,95	1
TURBOIL 3011 S/MMS	5,55	5,20	1
TURBOIL 6009 S & MMS	4,90	4,55	1
TURBOIL 6011 S/MMS	6,25	5,90	1
TURBOIL 7011 S/MMS	8,50	8,10	1
TURBOIL 8013 S & MMS	10,80	10,40	1
TURBOIL 9017 S/MMS	11,35	10,95	1

CARLY references	Unit weight kg		Packaging number of pieces
	With packaging	Without packaging	
TURBOIL-F 2505 S/MMS	5,25	4,95	1
TURBOIL-F 3007 S/MMS	5,60	5,30	1
TURBOIL-F 3009 S & MMS	6,10	5,75	1
TURBOIL-F 3011 S/MMS	7,20	6,85	1
TURBOIL-F 7011 S/MMS	12,10	11,70	1
TURBOIL-F 8013 S & MMS	14,35	13,95	1
TURBOIL-F 9017 S/MMS	15,90	15,50	1
TURBOIL-F 15013 S & MMS	19,05	17,85	1
TURBOIL-F 15017 S/MMS	22,15	20,95	1
TURBOIL-F 15021 S & MMS	22,85	21,65	1
TURBOIL-F 30025 S & MMS	23,95	22,75	1