



Replaceable core oil filter shells

→ HCYBF

■ Applications

- Oil filtering on the oil return line to the compressor sumps of high capacity refrigerating and air conditioning installations.
- These filters are essential for the proper functioning of oil level regulators and protect the compressors from contaminants that could damage them (metallic chips, filings, oxides, sludge, etc...); they allow the replacement of the oil filters' active parts only.
- These filters are recommended for the oil return lines of screw compressors and of centrifuge compressors.

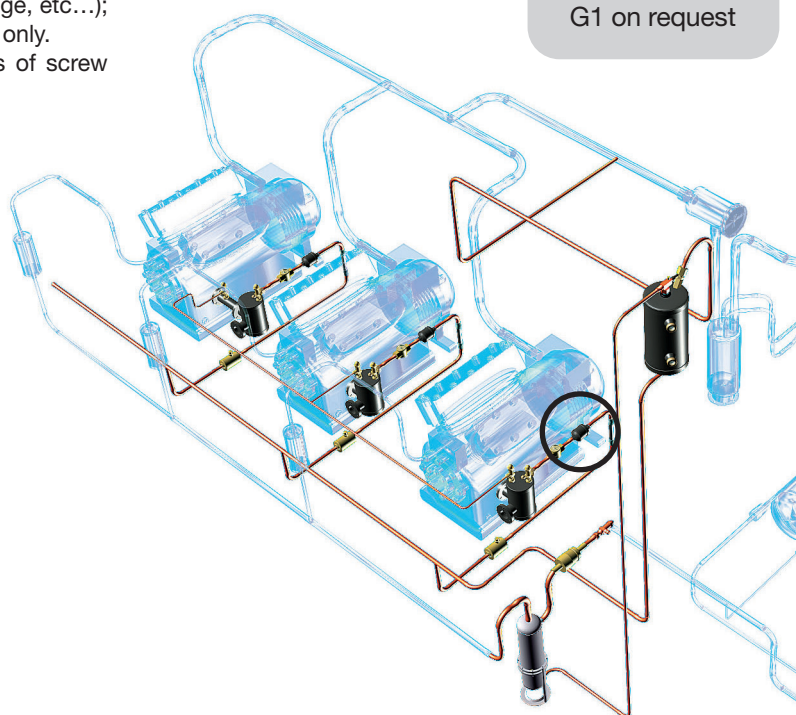

■ Functional features

- Products are compatible with HCFCs, HFCs, HFOs, CO₂, as well as with their associated oils and additives. Products are designed for use of non-hazardous refrigerants from group 2 of PED 2014/68/EU. To use CARLY components with fluids of the hydrocarbon group 1, contact CARLY technical department.
- Product classification in CE categories is performed using the PED 2014/68/EU table, corresponding to a volume-based selection.
- Hermetically sealed outer steel enclosure with paint to ensure a high resistance to corrosion.
- The oil filter shells are used with the CCY 48 HU filtrating cores (refer to chapter 8)
- 1/4" NPT taper tapping and its plug on the end plate, allowing the installation of a pressure tap or a feeding valve.
- End plate perfectly airtight thanks to its circular rim and its gasket compatible with all HFCs, HCFCs, HFOs, CO₂, as well as with their oils and associated additives.

Possible customization on demand:

- Specific connections.
- Larger number of cores: 2 and 3 cores.

■ CARLY advantages

- Individual core holders treated against corrosion by zinc-coating, with a reduced course to allow for core replacement; therefore, the time needed for replacement is extremely reduced, limiting oil core and inner circuit part exposition times to ambient atmosphere.
- Core holders are designed to ensure an automatic and immediate centring in the oil filter shell and an excellent distribution of the oil around the core, with a minimum pressure drop.
- CCY 48 HU oil core, filtering of 16 microns on a large surface.



Replaceable core oil filter shells

→ HCYBF

■ Warning

Before selecting or installing any component, please refer to the chapter 0 - **WARNING**.

■ General assembly precautions

The installation of a component in a refrigeration system by a skilled professional, requires some precautions:

- Some are specific to each component, and in this case, they are specified in the

RECOMMENDATIONS SPECIFIC part defined hereafter ;

- Other are general to all CARLY components, they are presented in the chapter 115 – **GENERAL ASSEMBLY PRECAUTIONS**.

- The recommendations relating to the CARLY components for the subcritical CO₂ applications are also developed in chapter 115 – **GENERAL ASSEMBLY PRECAUTIONS**.

■ Recommendations specific to the oil filter shells HCYBF

- The oil filter shells are to be mounted on the oil return line, between the oil separator and the oil level regulator, as close as possible to the latter.
- Mounting to be performed in whichever position, but not vertically with the outlet connection oriented downwards.
- The oil flow direction indicated by an arrow on the filter tag should be respected.
- When mounting the oil filter shells, provide for a sufficient course to allow the replacement of cores (refer to dimensions in Technical features tables).
- The level of blocking of the filtrating cores must be regularly checked, making

sure that the oil return is correct at the compressor crankcase. These filter cores must be imperatively replaced at the first sign of clogging.

- Oil filter shells selection should take into account the integration of the internal active element (cores CCY 48 HU); this integration can be temporary or permanent.
- It is highly recommended to install a HCYVP sight glass upstream of the oil filter shell (refer to chapter 48), in order to visually check the presence and condition of the oil.
- HCYBF oil filter shell only ensures

mechanical filtering of solid contaminants; to ensure optimal protection of the oil level regulators and of the compressors operating with very hydrophilous POE oils, it is imperative to use an HYDROIL filter drier for POE oils: refer to chapter 47.

- * Make sure that the piping can support without deformation the weight of the filter drier shell ; otherwise, provide for a clamp of the filter drier shell with a clamp on a stable part of the installation.



Replaceable core oil filter shells

→ HCYBF

■ CCY 48 HU core replacement procedure

- 1 • Isolate the **HCYBF** oil filter shell.
- 2 • Purge the installation up to atmospheric pressure (the shell should be empty of oil)
- 3 • Remove the end plate.
- 4 • Remove the core holders.
- 5 • Remove the used core.
- 6 • Clean very carefully the core holders as well as the inner part of the shell case.
- 7 • Replace systematically the end plate gasket.
- 8 • Remove the core from its packaging and put it in the core holder, separating by traction the two flanges holding the core holder (sketch 1)
- 9 • Put the core holders back into place with their core in the shell (sketch 2)
- 10 • Reinstall the closing flange making sure that the compression spring is correctly positioned and gradually and uniformly tighten the closing screws (refer to chapter 115 – GENERAL MOUNTING PRECAUTIONS – Criss-cross tightening). Maximum bolt tightening torque: 30 N.m.
- 11 • Make sure that the end plate's 1/4" NPT taper tapping has been properly plugged in and sealed.
- 12 • Make vacuum in the installation and check air-tightness of the whole set before putting back under pressure.

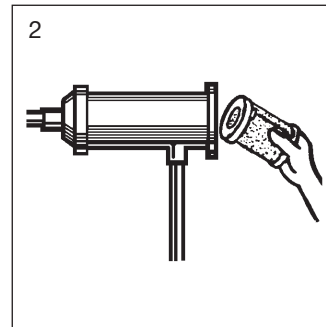
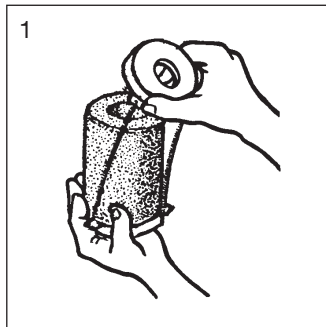



CTCY-EN - 46.1-6 / 06-2025

Replaceable core oil filter shells

→ HCYBF

■ Caractéristiques techniques

CARLY references	Connections To screw SAE pouce	Connections To solder ODF pouce	Connections To solder ODF mm	Filtering surface cm ²	Maximal admissible oil flow l/mn ⁽¹⁾	Drawing Nb	Connections types ⁽³⁾	Dimensions mm						Number of cores	
								Ø1	Ø2 ⁽²⁾	Ø3	L1	L2	E1		E2
HCYBF 485 S/MMS		5/8	16	5790	55	1	2	121	128	150	223	210	139	83,0	1
HCYBF 486 S		3/4		5790	70	1	2	121	128	150	225	210	148	86,0	1
HCYBF 486 N	3/4 NPT			5790	70	2	/	121	128	150	208	210	125	84,0	1

⁽¹⁾ These values take into account the capacity limitation linked to the connections flow area and to the performance average of the oil cores available on the market. For higher flow rates, it is recommended to install several shells in parallel.

⁽²⁾ With welding.

⁽³⁾ Chapter «Connection features and drawings» (refer to chapter 114).

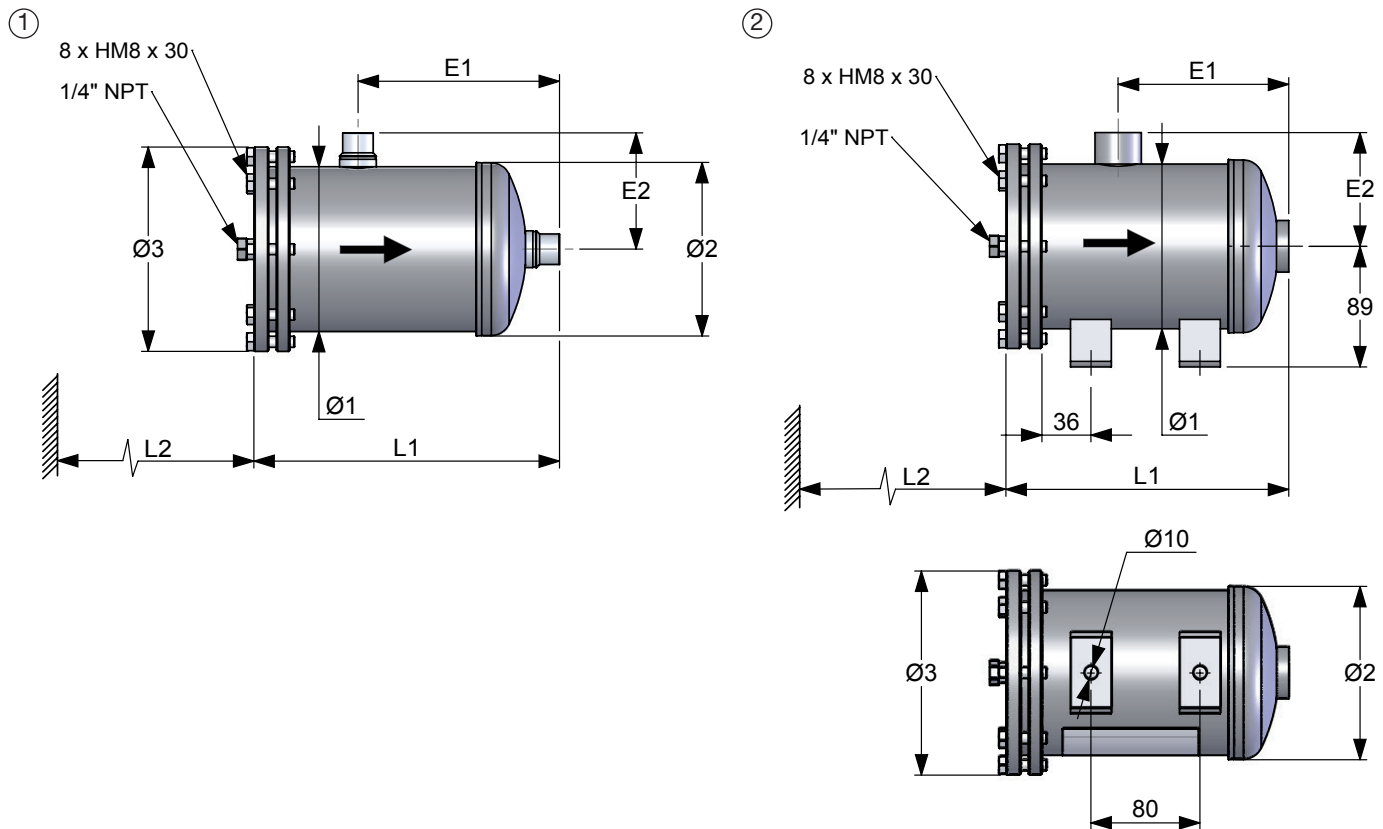

CARLY references	Volume	Maximal working pressure	Working pressure ⁽¹⁾	Maximal working temperature	Minimal working temperature	Working temperature ⁽¹⁾	CE Category ⁽²⁾
	V L	PS bar	PS BT bar	TS maxi °C	TS mini °C	TS BT °C	
HCYBF 485 S/MMS	1,9	35	15	100	-40	-30	I
HCYBF 486 S	1,9	35	15	100	-40	-30	I
HCYBF 486 N	1,9	35	15	100	-40	-30	I

⁽¹⁾ The working pressure is limited to the PS BT value when working temperature is lower than or equal to TS BT value.

⁽²⁾ Classification by volume, according to PED 2014/68/EU (refer to chapter 0).

Nota : Available Group 1 on request.



Replaceable core oil filter shells

→ HCYBF

■ Spare parts

CARLY references		Part N°	Description
Filter shells	Spare parts		
All HCYBF references	CY 19900411	1	Set of 8 fastening screws for end plate
	CY 10810010	2	1/4" NPT phosphate plug for end plate
	CY 33301200	2 + 3 + 5	1/4" NPT plug + End plate + gasket
	CY 37002010	4	Core holder
	CY 15555601	5	End plate gasket (red)

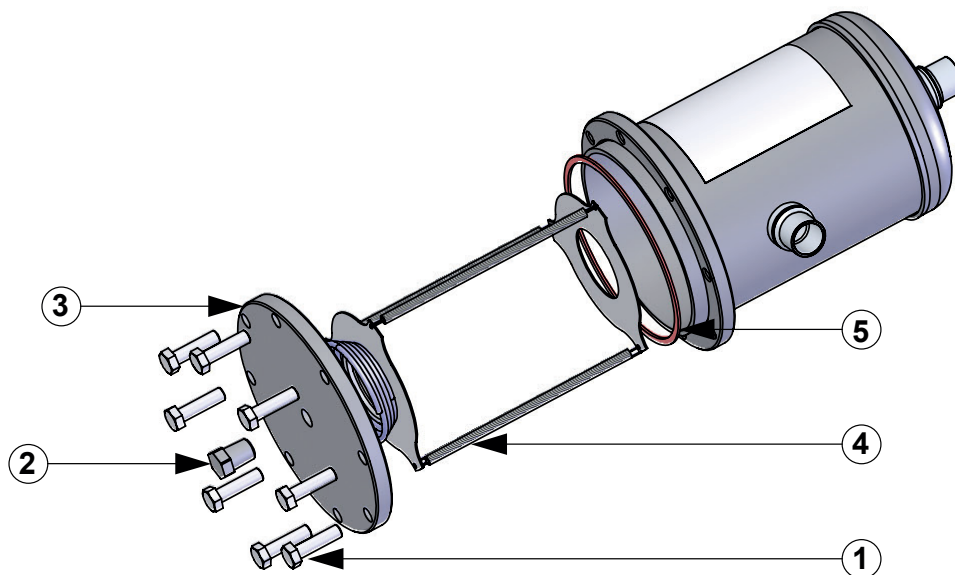

■ Weights and packaging

CARLY references	Unit weight kg		Packaging number of pieces
	With packaging	Without packaging	
HCYBF 485 S/MMS	4,55	4,30	1
HCYBF 486 S	4,60	4,35	1
HCYBF 486 N	4,70	4,45	1