



Mechanical oil level regulators and adapters

CTCY-EN - 49.1-13 / 06-2025

→ LEVOIL®

■ Applications

- Monitoring and automatic upholding of the optimal oil level in the crankcase of each compressor of refrigeration and air conditioning multi-compressors installations.
- The oil level regulators LEVOIL participate in the return of the oil into the compressors and to their proper functioning; they are only used in low pressure oil return systems.
- They allow the installation of compressors at unequal heights or different level of oil.
- They allow, on the same installation, the connection in parallel of compressors with different cooling capacities or operating at different regimes.

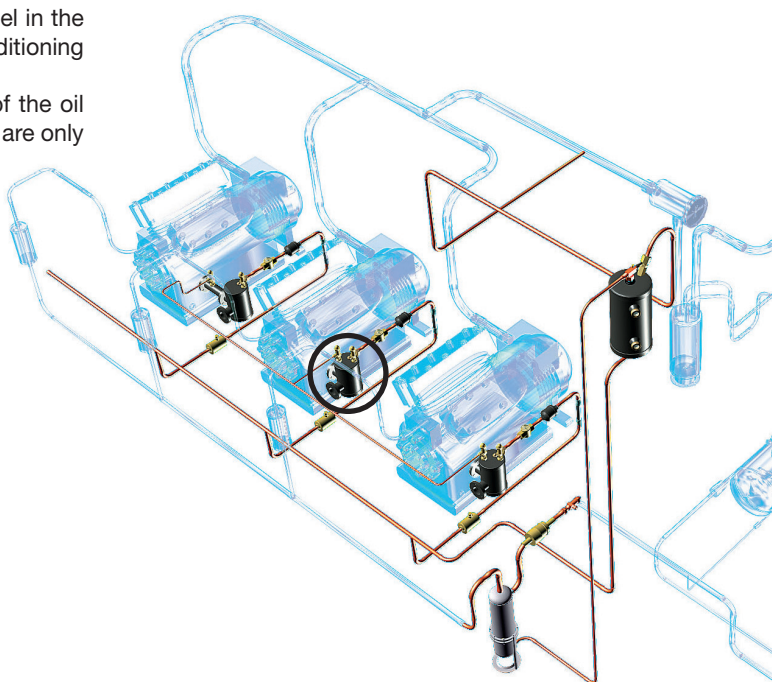

■ Functional features

- Products are compatible with HCFCs, HFCs, HFO, CO₂, as well as with their associated oils and additives. Products are designed for use of non-hazardous refrigerants from group 2 of PED 2014/68/EU. To use CARLY components with fluids of the hydrocarbon group 1 – contact CARLY technical department.
- Product classification in CE categories is done with the PED 2014/68/EU table, corresponding to a volume-based selection.
- Hermetically sealed outer steel enclosure with paint to ensure a high resistance to corrosion.
- Two connection flanges at 90° on the standard oil level regulator body allow for one, fastening on the compressor boss and for the other, the connection of the oil sight glass originally fixed on the compressor.
- 7 models of regulators with connecting flanges suitable for the main compressors of the market. One of them is adjustable, allowing to precisely adjust the oil level in accordance with the compressors' manufacturer recommendations; this model has also a pressure equalization connection, so the oil level of several compressors mounted in parallel can be equalized.

■ CARLY advantages

- Maximum working pressure 46 bar.
- Optimized range of oil level regulators equipped with two 7 holes universal flanges in order to be mounted on most of compressors available on the market.
- Resistance to higher pressure and limited foaming phenomenon inside the regulator due to the spherical design.
- Internal valve/needle/float oil return system, efficient and reliable. Minimizes the bad effect of foaming and ensures a good stability of the oil level.
- The density and viscosity of oils have nearly no effect on the regulator LEVOIL®.
- Due to the large pressure differential (1bar to 4,5bar), the basic model LEVOIL 23 is suitable for mounting on 2 levels cascade packs (supermarket application).
- Model LEVOIL 33 RE with adjustable ΔP from 1 to 6,5 bar and a pressure equalization connection.
- For the regulators with 7 holes flanges, the visualization of the oil level is facilitated, due to left or right mounting possibilities.
- Installation possible on the right or left side of the compressor, thanks to the centered inlet oil connection.
- Oil inlet connection inclined backwards, in order to avoid the cylinder heads of the compressor.
- Small volume of oil retention in the lower part of the LEVOIL®.
- Wide range of adapters allowing connection of the LEVOIL® on most of the compressors available on the market.



Mechanical oil level regulators and adapters

→ LEVOIL®

■ Functional features

- The sight-glasses' threads of some COPELAND® SCROLL® compressors, types ZB, ZS and ZF, having been changed by the manufacturer in May 2012 and in June 2014, CARLY offers the models of oil level regulators detailed in the chapter **COMPRESSORS / ADAPTERS ASSOCIATIONS**.
- The supplies delivered with the oil level regulators are detailed in the chapter "Technical features".

■ Warning

Before selecting or installing any component, please refer to the chapter 0 - **WARNING**.

■ General assembly precautions

The installation of a component in a refrigeration system by a skilled professional, requires some precautions:

- Some are specific to each component, and in this case, they are specified in the

RECOMMENDATIONS SPECIFIC part defined hereafter ;

- Other are general to all CARLY components, they are presented in the chapter 115 – **GENERAL ASSEMBLY PRECAUTIONS**.

- The recommendations relating to the CARLY components for the subcritical CO₂ applications are also developed in chapter 115 – **GENERAL ASSEMBLY PRECAUTIONS**.

■ Recommendations specific to the oil level regulators LEVOIL

- The oil level regulators must be bolted on the compressor bosses instead of the original oil level sight glass.
- It is imperative to use the items contained in the installation kit supplied with the regulator. The four-lobes gasket has to be used when connecting a sight glass or an adapter on the regulator (flanges with face to face grooves) see chapter "technical features".
- If the compressor crankcase does not offer a connection matching the flange of the standard oil level regulator, use a HCYN 1A adapter whose connection type will correspond to that of concerned compressors.
- Oil level regulator installation must be done only with the oil inlet located in the upper part.
- The oil receiver enables the feeding of oil level regulators, and it must be mounted two meters minimum above the oil level regulators; if it cannot be, it is necessary to mount a HCYCT – non adjustable – or HCYCTR – adjustable – differential valve on the oil receiver and to connect it to the suction line, in order to maintain overpressure in the receiver, ensuring:
 - continuous and regular oil feed of regulators
 - limitation of the pressure in the oil return line in the oil return line of the feeding
- of the oil level regulators, whose excess would hinder proper operation of regulators and be a source of incidents for the installation.
- Imperatively provide for an oil filter (HCYF, HCYBF or HYDROIL if polyol-ester oils, see chapters 45, 46 and 47) upstream of the oil level regulators in order to stop contaminants from disturbing their good operation.
- In order to perform perfect air-tightness with the connections to screw without gasket, it is recommended to use a thread sealing product.
- For the adjustable oil level regulators models (factory setting 3/4 glass):
 - turn the nut clockwise, to lower the oil level
 - turn the nut counter clockwise, to raise the oil level.
- In some cases, the vibrations generated by the compressors can disturb the oil level regulators operation; it is then imperative to eliminate causes of vibration.
- For correct operation, it is necessary to ensure, after mounting, that the oil level regulators are perfectly horizontal.
- Check that the oil quality is not degrading with time and regularly make some oil acidity tests (TESTOIL-MAS, TESTOIL -POE and TESTOIL-3P-CO₂; refer to chapter 91).
- Ensure that the pressure differential between the oil feeding and the compressor crankcase remains within the range recommended by CARLY.
- To select the optimal oil level, refer to the recommendations given by the compressor manufacturers; most of the time, this reference level is situated between the quarter and the half-sight glass.
- In the case of multi-compressor systems, it is recommended to use oil level regulators with a pressure equalization connection (LEVOIL 33 RE models), in order to get all the compressor crankcases at the same pressure.
- Replace the different gaskets each time the regulators or the sight glasses are taken out (see chapter "Spares parts").
- Replace the oil filter after each intervention on the oil system (change of oil, component replacement, etc...)







Mechanical oil level regulators and adapters

CTCY-EN - 49.1-13 / 06-2025

→ LEVOIL®

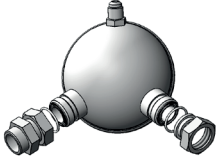
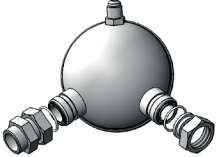
■ Technical features

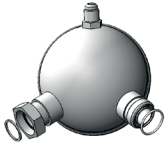
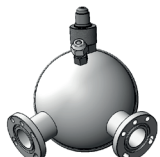
CARLY references	Type of connection	Pressure range bar	Oil inlet connection To screw SAE inch	Pressure equalization connection To screw SAE inch	Adjusted level	Installation kit (delivered with the product)
LEVOIL 22						
	7 holes Ø 6,5 mm	1 - 4,5	1/4"	/	Set ½ glass	4 screw HM6-30 4 nuts M6 4 washers Diam. 6 2 O-ring 1 quadring 1 fitting wedge for 4 holes sight glass
LEVOIL 23						
	7 holes Ø 6,5 mm	1 - 4,5	3/8"	/	Set ½ glass	4 screw HM6-30 4 nuts M6 4 washers Diam. 6 2 O-ring 1 quadring 1 fitting wedge for 4 holes sight glass
LEVOIL 23 BO						
	1" 1/8 - 18 UNEF	1 - 4,5	3/8"	/	Set ½ glass	1 sight glass 1" 1/4 - 12 UNF 2 PTFE gaskets 1 1" 1/8 - 18 UNEF adapter
LEVOIL 23 SC						
	3/4" NPTF	1 - 4,5	3/8"	/	Set ½ glass	1 sight glass 1" 1/4 - 12 UNF 2 PTFE gaskets 1 3/4" NPT adapter
LEVOIL 23 SC2						
	1" 3/4 - 12 UNF	1 - 4,5	3/8"	/	Set ½ glass	2 PTFE gaskets 1 sight glass 15/16" - 20
LEVOIL 23 SU						
	1" 1/4 - 12 UNF	1 - 4,5	3/8"	/	Set ½ glass	2 PTFE gaskets
LEVOIL 33 RE						
	7 holes Ø 6,5 mm	1 - 6,5	3/8"	1/4"	Adjustable between ¼ and ¾ - glass ⁽¹⁾	4 screw HM6-30 4 nuts M6 4 washers Diam. 6 2 O-ring 1 quadring 1 fitting wedge for 4 holes sight glass

See tables page 49.8, 49.9 and 49.10 for regulators and compressors association. ⁽¹⁾ Factory setting 3/4 glass



Mechanical oil level regulators and adapters

→ LEVOIL®

■ Technical features

CARLY references	Drawing Nb	Dimensions mm							Connections to flare SAE inch	
		L1	L2	L3	E1	E2	E3	E4	R1	R2
LEVOIL 22	1	115	127	150	57	120	28	/	1/4	/
LEVOIL 23	1	115	128	150	57	120	28	/	3/8	/
LEVOIL 23 B0	3	115	128	175	57	168	29	/	3/8	/
LEVOIL 23 SC	3	115	128	190	57	161	29	/	3/8	/
LEVOIL 23 SC2	5	115	128	150	57	122	29	/	3/8	/
LEVOIL 23 SU	4	115	128	152	57	124	29	/	3/8	/
LEVOIL 33 RE	2	115	155	151	60	131	39	92	3/8	1/4

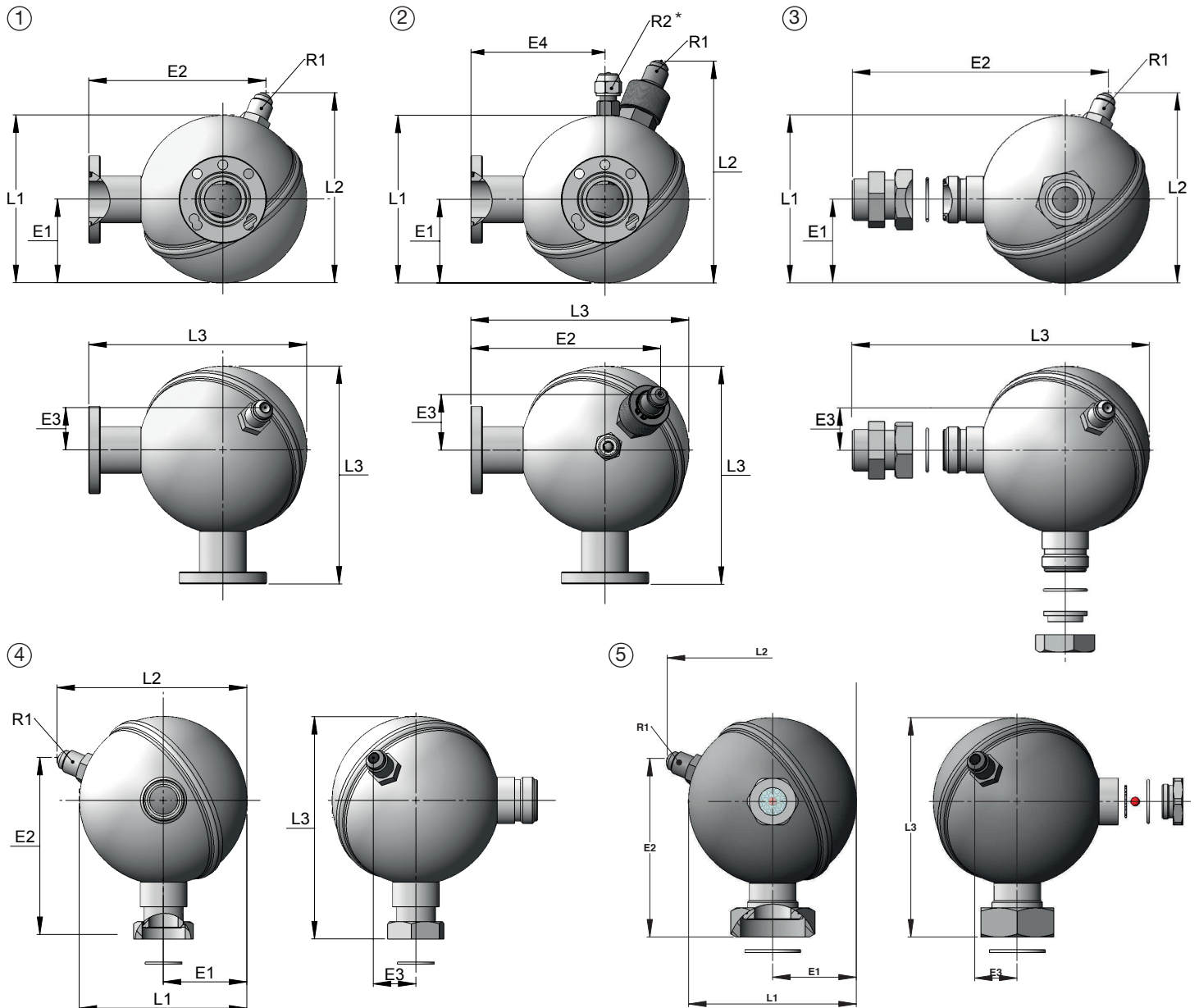



Mechanical oil level regulators and adapters

→ LEVOIL®

■ Technical features

CARLY references	Volume V L	Pressure range ΔP bar	Maximal working pressure		Working temperature		CE Category ⁽¹⁾	
			G2 bar	G1 bar	TS maxi °C	TS mini °C	With G2 fluids A1 and A2	With G1 fluids A2L, A2 and A3
LEVOIL 22	0,8	1 - 4,5	46,0	-	120	-20	Art 4.3	-
LEVOIL 23	0,8	1 - 4,5	46,0	46,0	120	-20	Art 4.3	Art 4.3
LEVOIL 23 BO	0,8	1 - 4,5	46,0	-	120	-20	Art 4.3	-
LEVOIL 23 SC	0,8	1 - 4,5	46,0	-	120	-20	Art 4.3	-
LEVOIL 23 SC2	0,8	1 - 4,5	46,0	-	120	-20	Art 4.3	-
LEVOIL 23 SU	0,8	1 - 4,5	46,0	-	120	-20	Art 4.3	-
LEVOIL 33 RE	0,8	1 - 6,5	46,0	-	120	-20	Art 4.3	-

⁽¹⁾ Classification by volume, according to PED 2014/68/EU (refer to chapter 0).

■ Example of selection

The selection of the oil level regulator **LEVOIL®** implies for the user to take into account all the conditions under which the product will be used (temperature - pressure - refrigerant - oil - external environment etc).

- Refrigerating unit composed of three compressors operating with R404A under the following conditions:
 - Compressors n° 1 and 2 $T_o = -10\text{ °C}$ $P_o = 4,4\text{ bar}$
 - Compressor n° 3 $T_o = -25\text{ °C}$ $P_o = 2,5\text{ bar}$
 - Use of a HCYCT 3 differential valve between the oil receiver and the suction collector that maintains a pressure differential of 1.4 bar.
 - Oil level regulation at half glass (according manufacturer's recommendation).
 - Inlet oil pipe diameter 3/8".

• Which **LEVOIL®** mechanical oil level regulator to choose?

- Calculation of the oil receiver pressure (P_{RH})

$$P_{RH} = P_o \text{ maxi} + \Delta P \text{ valve}$$

Result: $P_{RH} = 4.4 + 1.4 = 5.8\text{ bar}$

• LEVOIL® SELECTION FOR COMPRESSORS NO.1 AND NO.2

The pressure differential between the **HCYR** oil receiver and the common line compressors being of **1.40 bar** (given by the **HCYCT 3** differential valve), a **LEVOIL®** oil level regulator accepting a pressure differential of 1.4 bar has to be mounted on each of these compressors.

Result: LEVOIL 23

• LEVOIL® SELECTION FOR COMPRESSOR NO.3

The pressure differential between the **HCYR** oil receiver and compressor No.3 being of $5.8 - 2.5 = 3.3\text{ bar}$, a **LEVOIL®** oil level regulator accepting a pressure differential of 3.3 bar has to be mounted on the compressor.

Result: LEVOIL 23 / LEVOIL 33 RE



Mechanical oil level regulators and adapters

→ HCYN 1A

■ Technical features

HCYN 1A adapters allow connection of CARLY oil level regulators to compressors when it is not possible to connect the universal 7 holes flange directly on the compressors sight glass flange.

HCYN 1 EGA adapters enable to install several compressors in parallel.

CARLY references	Features of compressor connection (sight glass)	Accessories delivered with the adapter	End view from compressor side	Side view compressor on the right
HCYN 1EGA	4 screws 1/4" at 90° diameter 50 3 screws 1/4" diameter 47.6	4 screw HM6-30 4 nuts M6 4 washers Diam. 6 2 O-ring 1 quadring 1 fitting wedge for 4 holes sight glass		
HCYN 1A2	Threads 1 1/8" - 12	1 O-ring 3 screws HM6 - 30 cl 8 - 8 3 nuts HM6 3 washers DEC 6 1 glass 3 trous diameter 60		
HCYN 1A3	3 screws 1/4" diameter 47.6	1 O-ring 3 screws HM6 - 30 cl 8 - 8 3 nuts HM6 3 washers DEC 6		
HCYN 1A5	4 screws 1/4" diameter 50	1 O-ring 3 screws HM6 - 30 cl 8 - 8 3 nuts HM6 3 washers DEC 6 1 glass 3 holes diameter 60		
HCYN 1A9	4 screws 1/4" at 90° diameter 50	1 O-ring 3 screws HM6 - 30 cl 8 - 8 3 nuts HM6 3 washers DEC 6 1 glass 3 holes diameter 60		
HCYN 1A10	Threads 1 1/8" - 18	1 O-ring 3 screws HM6 - 30 cl 8 - 8 3 nuts HM6 3 washers DEC 6 1 glass 3 holes diameter 60		
HCYN 1A11	Threads 3/4" NPT	1 O-ring 3 screws HM6 - 30 cl 8 - 8 3 nuts HM6 3 washers DEC 6 1 glass 3 holes diameter 60		
HCYN 1A14	1 3/4 - 12 UNF ROTALOCK	1 O-ring 3 screws HM6 - 30 cl 8 - 8 3 nuts HM6 3 washers DEC 6 1 gasket PTFE 1 glass 3 holes diameter 60		
HCYN 1A15	1 1/4 - 12 UNF ROTALOCK	1 O-ring 3 screws HM6 - 30 cl 8 - 8 3 nuts HM6 3 washers DEC 6 1 gasket PTFE 1 glass 3 holes diameter 60		



Mechanical oil level regulators and adapters

CTCY-EN - 49.1-13 / 06-2025

→ HCYN 1A

■ Technical features

CARLY references	Drawing Nb	Dimensions mm		
		L1	L2	L
HCYN 1EGA	1	16,0	36,0	8,0
HCYN 1A2	2	58,5	84,5	26,0
HCYN 1A3	2	102,0	102,0	/
HCYN 1A5	2	57,5	82,5	25,0
HCYN 1A9	2	57,5	61,0	3,5
HCYN 1A10	2	46,5	57,5	11,0
HCYN 1A11	2	46,5	72,5	26,0
HCYN 1A14	2	60,5	71,5	11,0
HCYN 1A15	2	65,5	73,5	8,0

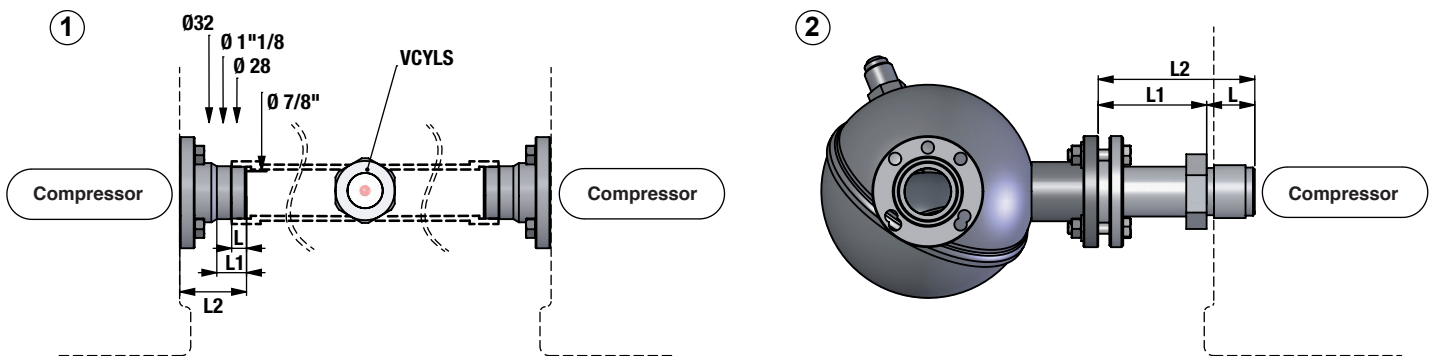

CARLY references	Nominal Diameter	Maximal working pressure	Maximal working temperature	Minimal working temperature	CE Category (1)
	DN mm	PS bar	TS maxi °C	TS mini °C	
HCYN 1EGA	21,7	46	120	-20	Art4§3
HCYN 1A2	21,7	46	120	-20	Art4§3
HCYN 1A3	21,7	46	120	-20	Art4§3
HCYN 1A5	21,7	46	120	-20	Art4§3
HCYN 1A9	21,7	46	120	-20	Art4§3
HCYN 1A10	21,7	46	120	-20	Art4§3
HCYN 1A11	21,7	46	120	-20	Art4§3
HCYN 1A14	21,7	46	120	-20	Art4§3
HCYN 1A15	21,7	46	120	-20	Art4§3

(1) Classification by diameter, according to PED 2014/68/EU (refer to chapter 0).



Mechanical oil level regulators and adapters

→ LEVOIL® + HCYN 1A

■ Compressors / Adapters associations

Compressor		Type of connection	Oil level regulator	Oil level regulator + adapter	BOOSTER application LP oil level regulator	Adjustable oil level regulator	Oil level regulator with equalisation
Brand	Range		1,0 bar < Δp < 4,5 bar		1,0 bar < Δp < 4,5 bar	1,0 bar < Δp < 6,5 bar	1,0 bar < Δp < 6,5 bar
BITZER	2CC --> 2KC 2CHC --> 2JHC	1" 1/8 - 18 UNEF	LEVOIL 23 B0	LEVOIL 22/23 + HCYN 1A10	LEVOIL 23 B0	LEVOIL 33 RE + HCYN 1A10	LEVOIL 33 RE + HCYN 1A10
	4CC --> 4FC, 4CHC --> 4FHC, 4NFR --> 4UFR, NFC --> UFC						
	ESH						
	2N, 2T, 4N, 4T, 4P, 4U, 4Z	4 holes in Ø 50 mm	LEVOIL 22/23	LEVOIL 22/23 (+ HCYN 1A5 for CP before 05/1997)	LEVOIL 22/23 (+ HCYN 1A5 for CP before 05/1997)	LEVOIL 33 RE (+ HCYN 1A5 for CP before 05/1997)	LEVOIL 33 RE (+ HCYN 1A5 pour CP before 05/1997)
	4FE, 4G, 4H, 4J, 4JE, 6F, 6G, 6H, 6J, W						
	S4, S6, S66						
	8D, 8E						
	4NG(S) --> 4VC(S), 4NHC --> 4VHC, 4NES --> 4VES, 4NDC --> 4VDC	3 holes in Ø 47,6 mm	LEVOIL 22/23		LEVOIL 22/23	LEVOIL 33 RE	LEVOIL 33 RE
	6D, 6E						
	8FC, 8GC						
	GSD 8	1" 3/4 - 12 UNF	LEVOIL 23SC2	LEVOIL 22/23 + HCYN 1A14	LEVOIL 22/23 + HCYN 1A14	LEVOIL 33 RE + HCYN 1A14	LEVOIL 33 RE + HCYN 1A14
BOCK	HA, HG, HGX (4, 5, 6)	3 holes in Ø 47,6 mm	LEVOIL 22/23		LEVOIL 22/23	LEVOIL 33RE	LEVOIL 33RE
	HG (7, 8) HGZ						
	EX	1" 1/8 - 18 UNEF	LEVOIL 23 B0	LEVOIL 22/23 + HCYN 1A10	LEVOIL 23 B0	LEVOIL 33 RE + HCYN 1A10	LEVOIL 33 RE + HCYN 1A10
	HA, HG, HGX (12, 22, 34)						
	AM (2 --> 5) F (2 --> 16)						
	CARRIER	EA, ER, 6E, OBE, OBCC	3 holes in Ø 47,6 mm	LEVOIL 22/23		LEVOIL 22/23	LEVOIL 33 RE
DA, DR, 5F, 5H, 6D, 6E		1" 1/2 - 18 UNEF	/	/	/	/	/



Mechanical oil level regulators and adapters

CTCY-EN - 49.1-13 / 06-2025

➔ LEVOIL® + HCYN 1A

■ Compressors / Adapters associations

Compressor		Type of connection	Oil level regulator	Oil level regulator + adapter	BOOSTER application LP oil level regulator	Adjustable oil level regulator	Oil level regulator with equalisation
Brand	Range		1,0 bar < Δp < 4,5 bar		1,0 bar < Δp < 4,5 bar	1,0 bar < Δp < 6,5 bar	1,0 bar < Δp < 6,5 bar
COPELAND	DK, DL, DN, ZR, ZZ	1" 1/8 - 12 UNF	/	LEVOIL 22/23 + HCYN 1A2	LEVOIL 22/23 + HCYN 1A2	LEVOIL 33 RE + HCYN 1A2	LEVOIL 33 RE + HCYN 1A2
	D2, D3, D4, D6, 4CC, 6CC	3 holes in Ø 47,6 mm	LEVOIL 22/23		LEVOIL 22/23	LEVOIL 33 RE	LEVOIL 33 RE
	D8, 8CC*		/	LEVOIL 33 RE + HCYN 1A3 (1/4 of sight glass)	LEVOIL 33 RE + HCYN 1A3	LEVOIL 33 RE + HCYN 1A3	LEVOIL 33 RE + HCYN 1A3
	ZB, ZBD (15 --> 48) (before 7/2014) ZS (15 --> 45) ZB, ZS 11/56/75/92 (before 5/2012) ZF 24 --> 48 (before 5/2012) ZF-K4E/KVE 06 --> 25 (before 7/2014) ZFD-K4E/KVE 13 --> 18 (before 7/2014) Z0	3/4" - 14 NPTF	LEVOIL 23 SC	LEVOIL 22/23 + HCYN 1A11	LEVOIL 23 SC	LEVOIL 33 RE + HCYN 1A11	LEVOIL 33 RE + HCYN 1A11
	ZR 11 --> 19, 90 ZR 94 --> 380 (after 8/2009) ZP 180, 235 --> 485 (after 8/2009) ZB, ZS 11/56/75/92/220 (after 5/2012) ZH (after 8/2009) ZF 24 --> 48 (after 5/2012)	1" 3/4 - 12 UNF ROTALOCK	LEVOIL 23 SC2	LEVOIL 22/ 23 + HCYN 1A14	LEVOIL 22/ 23 + HCYN 1A14	LEVOIL 33 RE + HCYN 1A14	LEVOIL 33 RE + HCYN 1A14
	ZR 94/108/125/144/160/190 (before 8/2009) ZB 15 --> 48 (after 7/2014) ZBD 21 --> 45 (after 7/2014) ZF-K4E/KVE 06 --> 25 (after 7/2014) ZFD-K4E/KVE 13 --> 18 (after 7/2014) ZB 50 --> 114 ZP 90 --> 182 (after 2007)	1" 1/4 - 12 UNF ROTALOCK	LEVOIL 23 SU	LEVOIL 22/23 + HCYN 1A15	LEVOIL 22/23 + HCYN 1A15	LEVOIL 33 RE + HCYN 1A15	LEVOIL 33 RE + HCYN 1A15
DANFOSS	MLM / MLZ / MFZ / LFZ / LLZ	1"1/8 - 18 UNEF	LEVOIL 23 B0	LEVOIL 22/23 + HCYN 1A10	LEVOIL 23 B0	LEVOIL 33 RE + HCYN 1A10	LEVOIL 33 RE + HCYN 1A10
	SH (090-->161)	1"3/4-12 UNF ROTALOCK	/	LEVOIL 22/23 + HCYN 1A14	LEVOIL 22/23 + HCYN 1A14	LEVOIL 33 RE + HCYN 1A14	LEVOIL 33 RE + HCYN 1A14
DORIN	H1, K (40CC --> 280CC) Hi (100-->240) SCC (180B-->280B)	1"1/8 - 18 UNEF	LEVOIL 23 B0	LEVOIL 22/23 + HCYN 1A10	LEVOIL 23 B0	LEVOIL 33 RE + HCYN 1A10	LEVOIL 33 RE + HCYN 1A10
	H2, H32, H4K, K4, K5, K6, KP, 2S, Y6, SC SCC (500 -->2500B) Hi (400 --> 1500)	3 holes in Ø 47,6 mm	LEVOIL 22/23		LEVOIL 22/23	LEVOIL 33 RE	LEVOIL 33 RE
	K7, K8, Y7	3 holes in Ø 47,6 mm	/	LEVOIL 22/23 + HCYN 1A3	LEVOIL 22/23 + HCYN 1A3	LEVOIL 33 RE + HCYN 1A3	LEVOIL 33 RE + HCYN 1A3
DUNHAM-BUSH	B6	3 holes in Ø 47,6 mm	LEVOIL 22/23		LEVOIL 22/23	LEVOIL 33 RE	LEVOIL 33 RE

* 3 screws on demand - CY 19900123



Mechanical oil level regulators and adapters

➔ LEVOIL® + HCYN 1A

■ Compressors / Adapters associations

Compressor		Type of connection	Oil level regulator	Oil level regulator + adapter	BOOSTER application LP oil level regulator	Adjustable oil level regulator	Oil level regulator with equalisation
Brand	Range		1,0 bar < Δp < 4,5 bar		1,0 bar < Δp < 4,5 bar	1,0 bar < Δp < 6,5 bar	1,0 bar < Δp < 6,5 bar
FRASCOLD	A,B,D,F,S,V,Z A-SK --> S-SK	3 holes in Ø 47,6 mm	LEVOIL 22/23		LEVOIL 22/23	LEVOIL 33 RE	LEVOIL 33 RE
	W	3 holes in Ø 47,6 mm	/	LEVOIL 22/23 + HCYN 1A3	LEVOIL 22/23 + HCYN 1A3	LEVOIL 33 RE + HCYN 1A3	LEVOIL 33 RE + HCYN 1A3
MANEUROP	All compressors with sight glass	1"1/8 - 18 UNEF	LEVOIL 23 B0	LEVOIL 22/23 + HCYN 1A10	LEVOIL 23 B0	LEVOIL 33 RE + HCYN 1A10	LEVOIL 33 RE + HCYN 1A10
PRESTCOLD	PK, PL	1"1/8 - 12 UNF	/	LEVOIL 22/23 + HCYN 1A2	LEVOIL 22/23 + HCYN 1A2	LEVOIL 33 RE + HCYN 1A2	LEVOIL 33 RE + HCYN 1A2
	P	3 holes in Ø 47,6 mm	LEVOIL 22/23		LEVOIL 22/23	LEVOIL 33 RE	LEVOIL 33 RE
	P8, P08	3 holes in Ø 47,6 mm	/	LEVOIL 22/23 + HCYN 1A3	LEVOIL 22/23 + HCYN 1A3	LEVOIL 33 RE + HCYN 1A3	LEVOIL 33 RE + HCYN 1A3
REFCOMP	SP	3 holes in Ø 47,6 mm	LEVOIL 22/23		LEVOIL 22/23	LEVOIL 33 RE	LEVOIL 33 RE
	SP (8 cyl)	3 holes in Ø 47,6 mm	/	LEVOIL 22/23 + HCYN 1A3	LEVOIL 22/23 + HCYN 1A3	LEVOIL 33 RE + HCYN 1A3	LEVOIL 33 RE + HCYN 1A3
TECUMSEH EUROPE	All compressors with sight glass	1"1/8 - 18 UNEF	LEVOIL 23 B0	LEVOIL 22/23 + HCYN 1A10	LEVOIL 23 B0	LEVOIL 33 RE + HCYN 1A10	LEVOIL 33 RE + HCYN 1A10
	SCROLL VSA	3/4-14 NPTF	LEVOIL 23 SC	LEVOIL 22/23 + HCYN 1A11	LEVOIL 23 SC	LEVOIL 33 RE + HCYN 1A11	LEVOIL 33 RE + HCYN 1A11
TRANE	M, R	3 holes in Ø 47,6 mm	LEVOIL 22/23		LEVOIL 22/23	LEVOIL 33 RE	LEVOIL 33 RE
	K	3/4-14 NPTF	LEVOIL 23 SC	LEVOIL 22/23 + HCYN 1A11	LEVOIL 23 SC	LEVOIL 33 RE + HCYN 1A11	LEVOIL 33 RE + HCYN 1A11
YORK	GC, GS, JS	3 holes in Ø 47,6 mm	LEVOIL 22/23		LEVOIL 22/23	LEVOIL 33 RE	LEVOIL 33 RE



Mechanical oil level regulators and adapters

CTCY-EN - 49.1-13 / 06-2025

→ LEVOIL® + HCYN 1A

■ Spare parts

CARLY references		Part Nb	Description
Regulators	Spare parts		
LEVOIL 22 / 23 / 33 RE	HCYN 1V1	2	Oil level sight glass for standard flange (3 holes)
LEVOIL 22 / 23 / 33 RE	HCYN 1V1K	1+2+3+5	Bolts (1) + Glass (2) + gaskets (3, 5)
LEVOIL 22 / 23 / 33 RE	CY 29900130	1+3+4+5	Bolts (1) + intermediate disk (4) + gaskets (3, 5)
LEVOIL 22 / 23 / 33 RE	CY 15552000	3	Quad ring
LEVOIL 22 / 23 / 33 RE	CY 15552190	5	O-ring
LEVOIL 23 SC / 23 B0 / 23 SU	CY 12850080	6	Sight glass 1" 1/4 ROTALOCK
LEVOIL 23 B0	CY 17637550	7	1" 1/8 -18 UNEF adapter
LEVOIL 23 SC	CY 17637490	7	3/4" NPT adapter
LEVOIL 23 SC / 23 B0 / 23 SU	CY 15580120	8	PTFE gasket
LEVOIL 23 SC2	CY 15580160	9	Gasket for 1" 3/4 ROTALOCK connection
LEVOIL 23 SC2	CY 15552180	10	O-ring PTFE gasket for sight glass
LEVOIL 23 SC2	CY 10501000	11	Colour ball for level visualization
LEVOIL 23 SC2	CY 35012150	12	Glass without moisture indicator

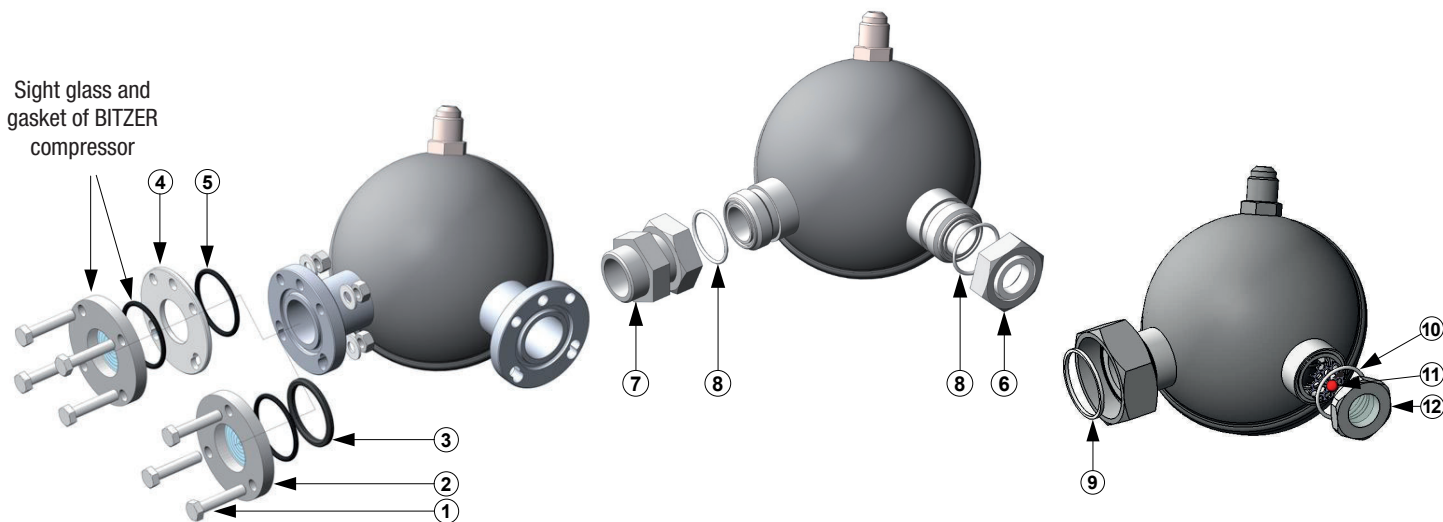

■ Weights and packaging

CARLY references	Unit weight kg		Packaging number of pieces
	With packaging	Without packaging	
LEVOIL 22	1,33	1,15	1
LEVOIL 23	1,33	1,16	1
LEVOIL 23 B0	1,26	0,95	1
LEVOIL 23 SC	1,27	1,10	1
LEVOIL 23 SC2	1,33	1,26	1
LEVOIL 23 SU	1,06	0,98	1
LEVOIL 33 RE	1,50	1,32	1

CARLY references	Unit weight kg		Packaging number of pieces
	With packaging	Without packaging	
HCYN 1EGA	0,26	0,26	1
HCYN 1A2	0,48	0,48	1
HCYN 1A3	0,50	0,50	1
HCYN 1A5	0,56	0,56	1
HCYN 1A9	0,57	0,57	1
HCYN 1A10	0,40	0,40	1
HCYN 1A11	0,46	0,46	1
HCYN 1A14	0,50	0,50	1
HCYN 1A15	0,42	0,42	1