

Replaceable core filter shells (suction line)

→ BDCY / ACY / BACY

■ Applications

- Cleaning, decontamination and protection of refrigerating and air conditioning installation refrigerant circuits.
- Suction replaceable core filter shells give the possibility to replace only active filter parts.

NEW
Fluid: A1, A2L (G2)

Shell reference	Core reference (size)
BDCY	CCY 42
ACY	CCY 48 / PLATINIUM 48
BACY	CCY 100 / PLATINIUM 100



Standard product



Customized product

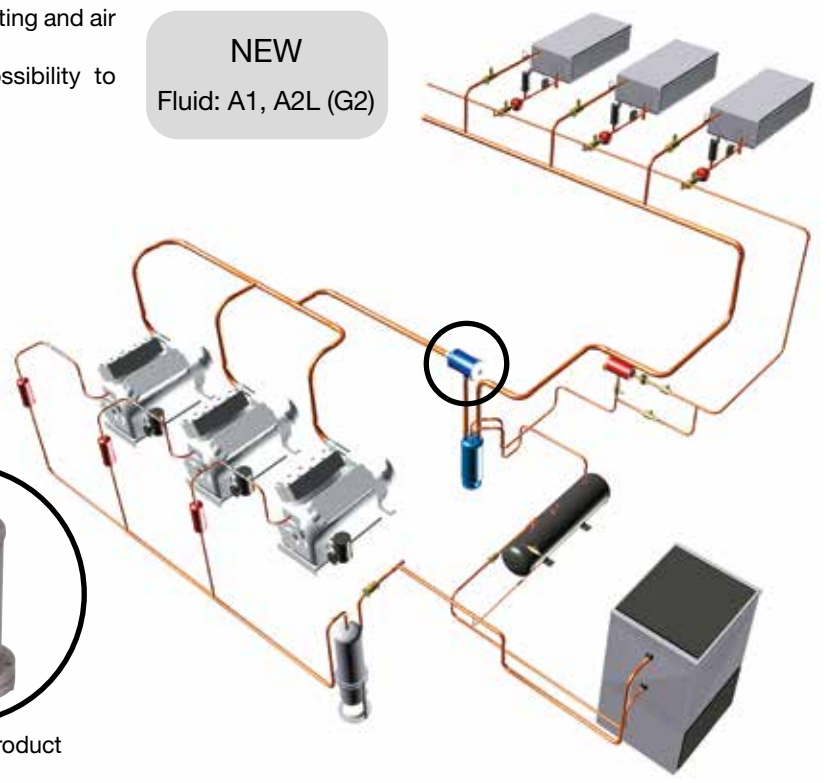

■ Functional features

- Products are compatible with HCFCs, HFCs, HFOs, CO₂, as well as with their associated oils and additives. Products are designed for use of non-hazardous refrigerants from group 2 of PED 2014/68/EU. To use CARLY components with fluids of security class A3 according EN378 and for a RANKINE organic cycle application, contact CARLY technical department.
- Product classification in CE categories is performed using the PED 2014/68/EU table, corresponding to a volume-based selection.
- Hermetically sealed external body in steel with paint to ensure a high resistance to corrosion.
- The suction filter shells also allow for CCY N cleaning cores, using CCY A adapters.
- 1/4" NPT taper tapping and its plug on end plate, allowing the installation of a pressure tap or a feeding valve.
- End plate perfectly tight thanks to its circular rim and its gasket compatible with all CFCs, HCFCs, HFOs and CO₂s.



Possible customization on demand:

- Stainless steel body and connections (Corrosion resistance and for use at very low temperature)

■ CARLY advantages

- Maximum working pressure up to 33 bars for use with R 410 A and CO₂
- Individual core holder treated against corrosion by zinc-coating, with a reduced course for core replacement; therefore, replacement time is extremely reduced, limiting drier filter cores and inner circuit part exposition times to ambient atmosphere.
- Hermetically sealed external body made of steel to which an impregnation varnish and paint are applied to ensure a high resistance to corrosion ; this varnish ensures the internal anti-corrosion protection of the shell when it is opened for the initial set-up or during the replacement of the drying cores.
- Core holders are designed to ensure automatic and immediate centring of the filter shells.
- No flow area restriction outside the filter shells thanks to an appropriate filtering system.
- Low suction filter shells case footprint, for large section piping.
- In the case of use of CCY F felt filtering cores or CCY I stainless steel mesh cloth cores, the refrigerant can operate in both directions.



Replaceable core filter shells (suction line)

→ BDCY / ACY / BACY

■ Warning

Before selecting or installing any component, please refer to the chapter 0 - **WARNING**.

■ General assembly precautions

The installation of a component in a refrigeration system by a skilled professional, requires some precautions:

- Some are specific to each component, and in this case, they are specified in the

RECOMMENDATIONS SPECIFIC part defined hereafter ;

- Other are general to all CARLY components, they are presented in the chapter 115 – **GENERAL ASSEMBLY PRECAUTIONS**.

- The recommendations relating to the CARLY components for the subcritical CO₂ applications are also developed in chapter 115 – **GENERAL ASSEMBLY PRECAUTIONS**.

■ Specific recommendations to replaceable core suction filter shells BDCY / ACY / BACY

- Suction filter shells are to be mounted on the suction line between the evaporator and the compressor.
- The refrigerant flow direction, indicated by an arrow on the suction filter shells' tags, should be complied with, unless CCY F felt cores or CCY I stainless steel mesh cloth cores are being used.
- The mounting is performed in any position except vertically with the outlet union facing downward and as close as possible to the compressor.
- Suction filter shells should be installed so that they do not create an oil trap.
- While mounting the suction filter shells, a sufficient course should be provided to allow for core replacement (refer to sizes L2 in technical features tables).
- The connection to the installation, by soldering or welding, of the suction filter shell, must be done only after removing the closing flange, its gasket and the internal core holders.
- We recommend to clean and to protect the connections after brazing, with adapted products to insure good corrosion resistance of the affected zone.
- Make sure that the piping can stand the weight of the core filter shell without any deformation. Otherwise, plan to fix the core filter shell to a stable part of the installation with a hose clip.
- Do not forget to mount CCY A adaptors, when suction filter shells are used with CCY HP, CCY N and PLATINIUM 48 cores.
- Suction filter shells selection should take into account the integration of internal active elements (cores); this integration can be temporary or permanent.
- In order to avoid risk of frost and condensation on the suction filter shells mounted on a cold pipe, it is recommended to insulate them thermally.
- For mounting the cap or 1/4» NPT fitting, we advise to follow the following procedure:
 - Clean and degrease the surfaces
 - Apply two to three turns of 100% P.T.F.E. H.D. sealing strip, or apply a 360° anaerobic sealing cord on the male and female thread, avoiding the first thread.
 - Assemble the fittings using a torque wrench up to 25N.m

Replaceable core filter shells (suction line)

→ BDCY / ACY / BACY

■ Circuit cleaning procedure after compressor burnout for installations equipped with suction filter shells: BDCY / ACY / BACY

- 1 • According to the model, install the corresponding **CCY A** adapter in the shell (Refer to chapter 7 for the **BDCYs**, **ACYs** and **BACYs**) then the corresponding **CCY N** cleaning core(s) (refer to chapter 8).
- 2 • Let the installation run for 3 hours maximum, carefully monitoring the internal pressure drop indicating a saturation of the cores that should then be quickly replaced. This phase aims at retrieving moisture, acids, waxes and varnishes from the circuit; it is necessary to repeat it until this objective is reached (acidity and moisture monitoring).
- 3 • Replace the **CCY N** cleaning core(s) by **CCY F** felt cores after having carefully removed the **CCY A** adapter.
- 4 • Let the installation run for several days, closely monitoring the internal pressure drop, which would mean that **CCY Fs** are blocked by the contaminating agents, and should then be quickly replaced. This phase aims at eliminating all undesirable solid particles from the circuit.
- 5 • After several days of operating, replace the felt cores **CCY F** by the stainless steel mesh cloth **CCY I**, which will stay permanently on the installation to protect the compressor.

👉 It is imperative to regularly monitor the refrigerant's moisture content and condition using the sight glasses with **CARLY VCYL** or **VCYLS** moisture indicators (refer to chapters 9 or 10).

👉 Use replaceable **CCY** cores (refer to chapter 8) for refrigerating circuit cleaning, decontamination and pollution control after compressor burnout.

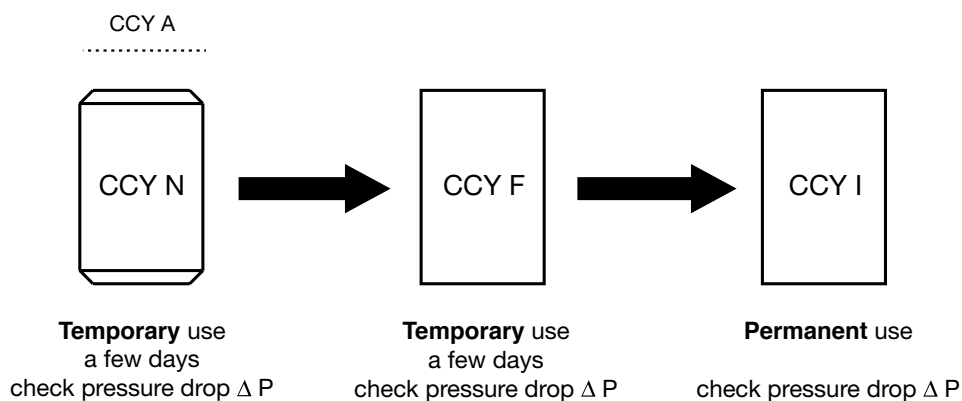



Replaceable core filter shells (suction line)

→ **BDCY** (corresponding cores: CCY 42)

■ Core replacement procedure

- 1 • Isolate the **BDCY** suction filter shell.
- 2 • Purge the installation up to atmospheric pressure (shell should be empty of refrigerants)
- 3 • Remove the end plate.
- 4 • Remove the bottom core holder.
- 5 • Remove the used core.
- 6 • The **CCY A 42** adapter should be used with **CCY 42 HP** and **CCY 42 N** cores but should imperatively be removed if **CCY 42 F** and **CCY 42 I** cores are being used.
- 7 • Clean and replace if necessary, the **CCY A 42** adapter and the outlet screen.
- 8 • Check and replace if necessary, the outlet gasket of the top core holder.
- 9 • Replace systematically the gasket on the end plate.
- 10 • Remove the **CCY 42** core from its can.
- 11 • Reassemble in order (see drawing below): the outlet screen (1), the **CCY A 42** adapter (2) if necessary, the outlet gasket (3), the top core holder (4), the **CCY 42** core, the bottom core holder and its compression spring (5)
- 12 • Reinstall the closing flange making sure that the compression spring is correctly positioned and gradually and uniformly tighten the closing screws (refer to chapter 115 – **GENERAL MOUNTING PRECAUTIONS** – Criss-cross tightening). Maximum bolt tightening torque: 30 N.m.
- 13 • Make sure that the end plate's 1/4" NPT taper tapping has been properly plugged in and sealed.
- 14 • Make vacuum in the installation and check air-tightness of the whole set before putting back under pressure.

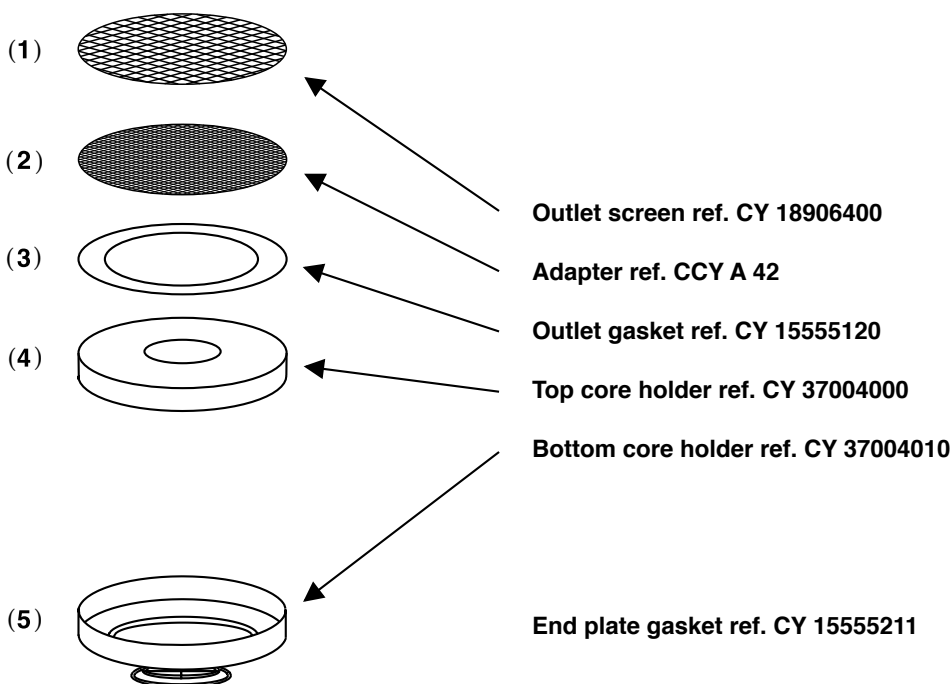

Replaceable core filter shells (suction line)

CTCY-EN - 6.1-9 / 09-2023

→ BDCY (corresponding cores: CCY 42)

■ Selection table

CARLY references	Connections To solder ODF		Refrigerating capacity kW ⁽¹⁾					Refrigerating capacity kW ⁽¹⁾					Number of cores
			Temporary use with CCY 42 N - CCY 42 F					Permanent use with CCY 42 I					
			R1233zd	R22 R134a R407C R410A R407F	R404A R507A R452A	R1234ze R513A R448A R449A R450A R455A	R744	R1233zd	R22 R134a R407C R410A R407F	R404A R507A R452A	R1234ze R513A R448A R449A R450A R455A	R744 ⁽²⁾	
inch	mm												
BDCY 424 S	1/2		1	10	7	9	12	2	15	10	13	18	1
BDCY 424 MMS		12	1	10	7	9	12	2	15	10	13	18	1
BDCY 425 S/MMS	5/8	16	2	14	10	12	16	3	20	15	17	25	1
BDCY 427 S/MMS	7/8	22	3	20	15	17	22	5	39	28	34	48	1

⁽¹⁾ Refrigerating capacities according to Standard ARI 730-2001 for $T_o = 4.4\text{ }^\circ\text{C}$, $T_k = 32\text{ }^\circ\text{C}$.

⁽²⁾ Refrigerating capacities Q_n for $T_k = -10\text{ }^\circ\text{C}$ and $T_o = -40\text{ }^\circ\text{C}$.
If different conditions, refer to correction factors in chapter 112.

If different conditions, refer to correction factors in chapter 112.

Nota: the diameter of connections must not be inferior to the diameter of the main pipe.

■ Technical features

CARLY references	Connection types ⁽¹⁾	Filtering surface cm ²			Dimensions mm							
		CCY 42 HP CCY 42 N	CCY 42 F	CCY 42 I	Ø1	Ø2	Ø3	L1	L2	E1	E2	
BDCY 424 S	BDCY 424 MMS	2	374	329	348	89	96	124	218	210	152	65
BDCY 425 S/MMS		2	374	329	348	89	96	124	220	210	155	67
BDCY 427 S/MMS		2	374	329	348	89	96	124	230	210	163	76

⁽¹⁾ Chapter «Connection features and drawings» (refer to chapter 114).

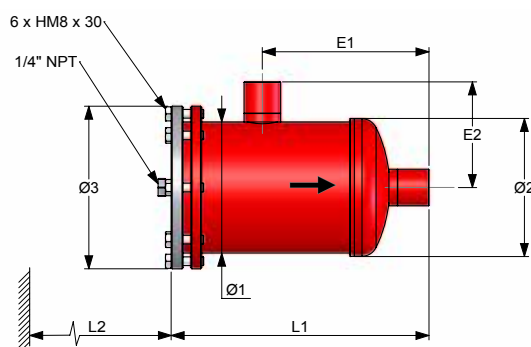

CARLY references	Volume V L	Maximal working pressure PS bar	Working pressure ⁽¹⁾ PS BT bar	Maximal working temperature TS maxi °C	Minimal working temperature TS mini °C	Working temperature ⁽¹⁾ TS BT °C	CE Category ⁽²⁾	
								BDCY 424 S
BDCY 425 S/MMS		1,00	42	15	100	-40	-30	Art4§3
BDCY 427 S/MMS		1,00	42	15	100	-40	-30	Art4§3

⁽¹⁾ The working pressure is limited to the PS BT value when working temperature is lower than or equal to TS BT value.

⁽²⁾ Classification by volume, according to PED 2014/68/EU (refer to chapter 0).



Replaceable core filter shells (suction line)

→ **BDCY** (corresponding cores: CCY 42)

■ Spare parts

CARLY references	Part N°	Description	Quantity
CY 19900410	1	Set of 6 fastening screws for end plate	1
CY 19910410	1	Set of 6 fastening stainless steel screws for end plate	1
CY 10810010	2	1/4" NPT phosphate plug for end plate	1
CY 33301000	2 + 3 + 5	End plate with gasket and 1/4" NPT plug	1
CY 37004010	4	Bottom core holder	1
CY 15555211	5	End plate gasket (red)	1
CY 37004000	6	Top core holder	1
CCY A 42	7	Adapter for end core holders	1

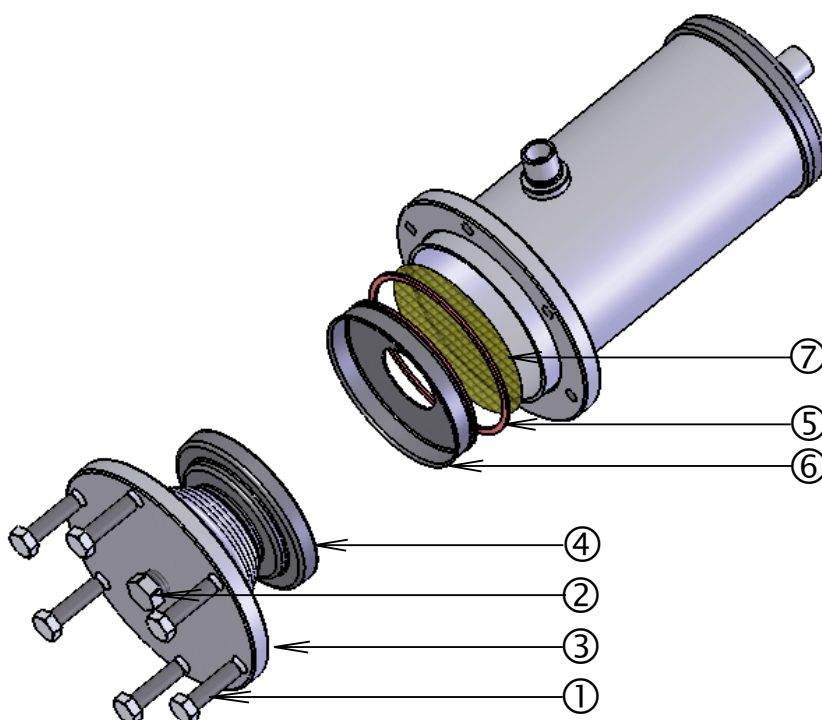

■ Weights and packaging

CARLY references	Unit weight kg		Packaging number of pieces
	With packaging	Without packaging	
BDCY 424 S & MMS	2,85	2,60	1
BDCY 425 S/MMS	2,90	2,65	1
BDCY 427 S/MMS	2,95	2,70	1

Replaceable core filter shells (suction line)

→ **ACY** (corresponding cores: *CCY 48* and *PLATINIUM 48*)

■ Core replacement procedure

- 1 • Isolate the **ACY** suction filter shell.
- 2 • Purge the installation up to atmospheric pressure (shell should be empty of refrigerants)
- 3 • Remove the end plate.
- 4 • Remove the core holders one after the other.
- 5 • Remove the used cores.
- 6 • Clean very carefully the core holders, the **CCY A 48** adapter and the inner part of the shell case.
- 7 • Replace systematically the gasket on the end plate and check core holders gaskets.
- 8 • Remove the core from its can and put it on the core holder, separating by traction the two flanges that hold the core holder (sketch 1) if necessary, install the **CCY A 48** adapter in end core holder.
- 9 • Repeat the operation for each core holder.
- 10 • Quickly install the core holders with their cores in the shell complying with their mounting order: the first one holds the screen and the adapter, if any, and the last one is equipped with a compression spring (sketch 2)
- 11 • Reinstall the closing flange making sure that the compression spring is correctly positioned and gradually and uniformly tighten the closing screws (refer to chapter 115 – **GENERAL MOUNTING PRECAUTIONS** – Criss-cross tightening). Maximum bolt tightening torque: 30 N.m.
- 12 • Make sure that the end plate's 1/4" NPT taper tapping has been properly plugged in and sealed.
- 13 • Make vacuum in the installation and check air-tightness of the whole set before putting back under pressure.

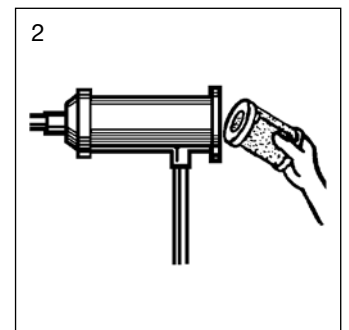
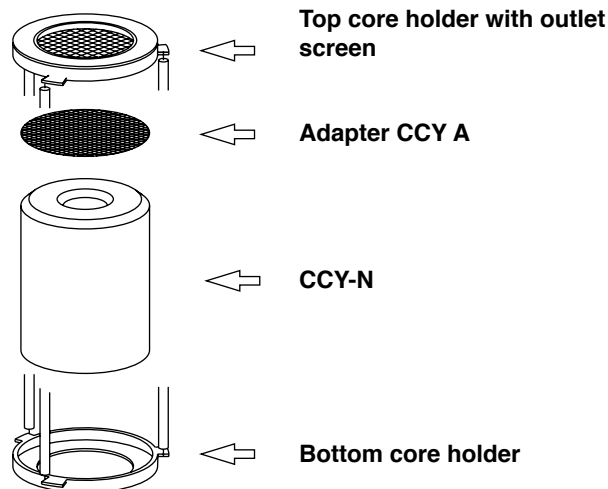
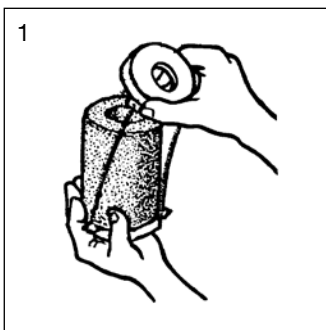



Replaceable core filter shells (suction line)

➔ **ACY** (corresponding cores: CCY 48 and PLATINIUM 48)

■ Selection table

CARLY references	Connections To solder ODF		Refrigerating capacity kW ⁽¹⁾					Refrigerating capacity kW ⁽¹⁾					Number of cores
			Utilisation temporaire avec CCY 48 N - CCY 48 F					Permanent use with CCY 48 I					
			R22 R407F R407C R404A R448A R449A R452A R507A	R134a R513A R450A R1234ze	R1234zd	R410A	R744	R22 R407F R407C R404A R448A R449A R452A	R134a R513A R450A R1234ze	R1234zd	R410A	R744 ⁽²⁾	
inch	mm												
ACY 489 S	1 1/8		51	46	5	60	62	83	76	8	90	93	1
ACY 489 MMS		28	51	46	5	60	62	83	76	8	90	93	1
ACY 4811 S/MMS	1 3/8	35	60	55	6	72	75	101	92	10	109	114	1
ACY 4813 S	1 5/8		67	61	7	79	83	119	108	12	129	134	1
ACY 4813 MMS		42	67	61	7	79	83	119	108	12	129	134	1
ACY 4817 S/MMS	2 1/8	54	73	67	7	87	91	144	131	14	156	162	1
ACY 4821 S	2 5/8		80	73	8	95	99	173	158	17	187	194	1
ACY 4821 MMS		67	80	73	8	95	99	173	158	17	187	194	1
ACY 4825 S	3 1/8		86	78	9	101	105	178	162	18	192	200	1
ACY 4825 MMS		80	86	78	9	101	105	178	162	18	192	200	1
ACY 9617 S/MMS	2 1/8	54	100	91	10	118	123	176	160	18	190	198	2
ACY 9621 S	2 5/8		103	94	10	122	127	202	184	20	218	227	2
ACY 9621 MMS		67	103	94	10	122	127	202	184	20	218	227	2
ACY 9625 S	3 1/8		107	97	11	126	131	254	231	25	274	285	2
ACY 9625 MMS		80	107	97	11	126	131	254	231	25	274	285	2
ACY 19217 S/MMS	2 1/8	54	130	119	13	155	161	214	195	21	231	240	4
ACY 19221 S	2 5/8		135	123	14	160	166	249	227	25	269	279	4
ACY 19221 MMS		67	135	123	14	160	166	249	227	25	269	279	4
ACY 19225 S	3 1/8		144	131	14	170	177	313	286	31	338	351	4
ACY 19225 MMS		80	144	131	14	170	177	313	286	31	338	351	4

⁽¹⁾ Refrigerating capacities according to Standard ARI 730-2001 for $T_o = 4.4\text{ °C}$, $T_k = 32\text{ °C}$.
If different conditions, refer to correction factors in chapter 112.

⁽²⁾ Refrigerating capacities Q_n for $T_k = -10\text{ °C}$ and $T_o = -40\text{ °C}$
If different conditions, refer to correction factors in chapter 112.

Nota: the diameter of connections must not be inferior to the diameter of the main pipe.

Replaceable core filter shells (suction line)

CTCY-EN - 6.1-9 / 09-2023

➔ **ACY** (corresponding cores: CCY 48 and PLATINIUM 48)

■ Technical features

CARLY references		Connection types ⁽¹⁾	Filtering surface cm ²	Dimensions mm						
				Ø1	Ø2 ⁽²⁾	Ø3	L1	L2	E1	E2
ACY 489 S	ACY 489 MMS	3	420	121	128	150	238	210	154	98
ACY 4811 S/MMS		3	420	121	128	150	247	210	163	108
ACY 4813 S	ACY 4813 MMS	3	420	121	128	150	247	210	163	108
ACY 4817 S/MMS		3	420	121	128	150	260	210	176	124
ACY 4821 S	ACY 4821 MMS	3	420	121	128	150	270	210	182	128
ACY 4825 S	ACY 4825 MMS	3	420	121	128	150	280	210	189	132
ACY 9617 S/MMS		3	840	121	128	150	400	210	316	124
ACY 9621 S	ACY 9621 MMS	3	840	121	128	150	410	210	322	128
ACY 9625 S	ACY 9625 MMS	3	840	121	128	150	420	210	329	132
ACY 19217 S/MMS		3	1260	121	128	150	685	210	601	124
ACY 19221 S	ACY 19221 MMS	3	1680	121	128	150	695	210	607	128
ACY 19225 S	ACY 19225 MMS	3	1680	121	128	150	705	210	614	132

⁽¹⁾ Chapter "Connection features and drawings" (refer to chapter 114).

⁽²⁾ Including weld.

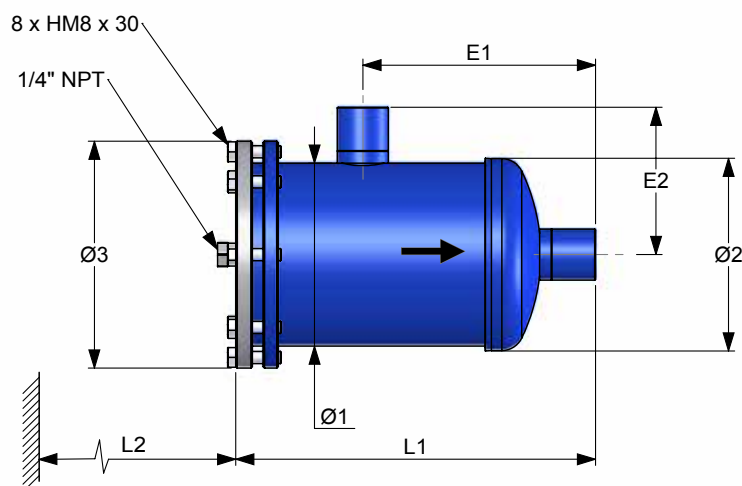



Replaceable core filter shells (suction line)

→ **ACY** (corresponding cores: CCY 48 and PLATINIUM 48)

■ Technical features

CARLY references		Volume	Maximal working pressure	Working pressure ⁽¹⁾	Maximal working temperature	Minimal working temperature	Working temperature ⁽¹⁾	CE Category ⁽²⁾
ACY 489 S	ACY 489 MMS	1,92	33	15	80	-40	-30	I
ACY 4811 S/MMS		1,93	33	15	80	-40	-30	I
ACY 4813 S	ACY 4813 MMS	1,95	33	15	80	-40	-30	I
ACY 4817 S/MMS		2,04	33	15	80	-40	-30	I
ACY 4821 S	ACY 4821 MMS	2,18	33	15	80	-40	-30	I
ACY 4825 S	ACY 4825 MMS	2,30	33	15	80	-40	-30	I
ACY 9617 S/MMS		3,40	33	15	80	-40	-30	I
ACY 9621 S	ACY 9621 MMS	3,60	33	15	80	-40	-30	I
ACY 9625 S	ACY 9625 MMS	3,70	33	15	80	-40	-30	I
ACY 19217 S/MMS		6,50	29 *	15	80	-40	-30	I
ACY 19221 S	ACY 19221 MMS	6,70	29 *	15	80	-40	-30	I
ACY 19225 S	ACY 19225 MMS	6,80	29 *	15	80	-40	-30	I

⁽¹⁾ The working pressure is limited to the PS BT value when working temperature is lower than or equal to TS BT value.

⁽²⁾ Classification by volume, according to PED 2014/68/EU (refer to chapter 0).

* 33 bar working pressure possible on demand



Replaceable core filter shells (suction line)

→ ACY (corresponding cores: CCY 48 and PLATINIUM 48)

■ Core holders and gaskets

Shells	CARLY References for core holders	Quantity and type of gaskets for use	
		Core holders gasket ⁽¹⁾	End plate gasket ⁽²⁾
ACY 1 core	CY 37001050	1 gasket CY 1555200	
ACY 2 cores	CY 37001030 + CY 37001060	2 gaskets CY 1555200	1 gasket CY 1555601
ACY 3 cores	CY 37001030 + CY 37001040 + CY 37001060	3 gaskets CY 1555200	
ACY 4 cores	CY 37001030 + CY 37001040 + CY 37001040 + CY 37001060	4 gaskets CY 1555200	

⁽¹⁾ Gasket delivered with core holders

⁽²⁾ Gasket delivered with cores CCY 48 HP, CCY 48 N, CCY 48 I, CCY 48 F and PLATINIUM 48

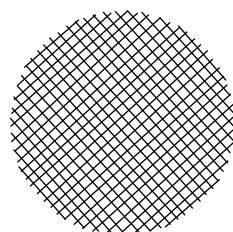
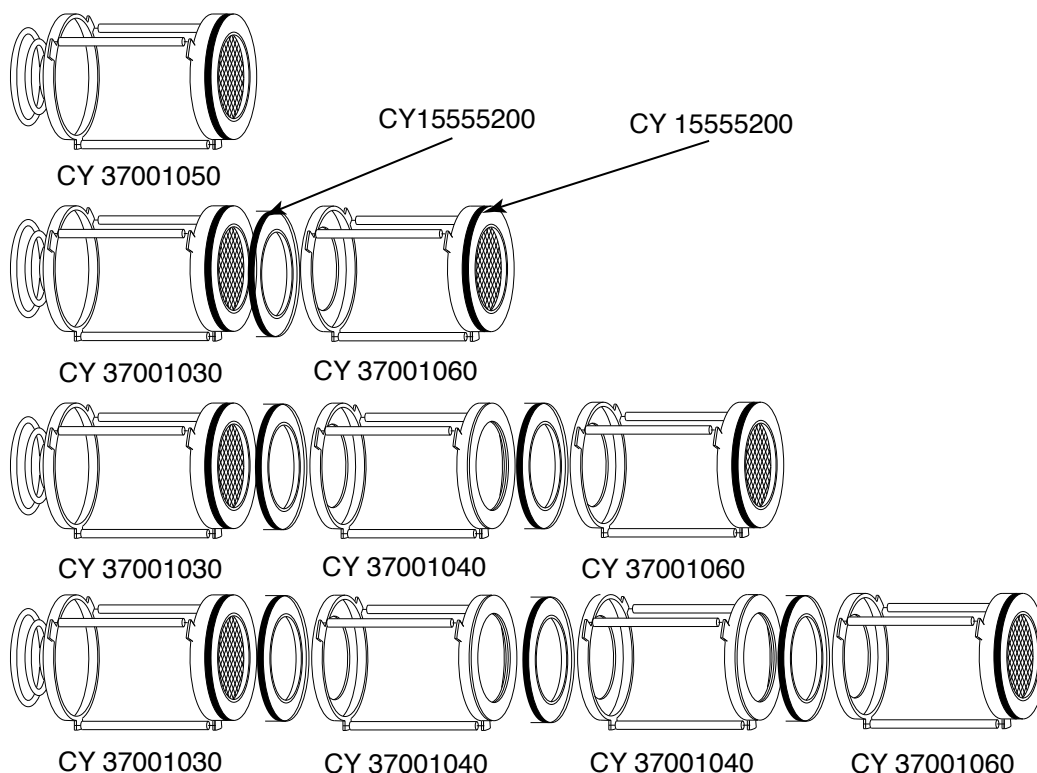

- Outlet filter adapter for ACY:
CCY A 48 (To use with cores CCY 48 HP, PLATINIUM 48 and CCY 48 N).
- The adapter **CCY A 48** shall be installed in top flange of core holder:
CY 37001050 for one core ACY and
CY 37001060 for several cores ACY.



Replaceable core filter shells (suction line)

→ **ACY** (corresponding cores: CCY 48 and PLATINIUM 48)

■ Spare parts

CARLY references	Part N°	Description	Quantity
CY 19900411	1	Set of 8 fastening screws for end plate	1
CY 19910411	1	Set of 8 fastening stainless steel screws for end plate	1
CY 10810010	2	1/4" NPT phosphate plug for end plate	1
CY 33301200	2 + 3 + 5	End plate with gasket and 1/4" NPT plug	1
CY 37001030	4	Core holder (2, 3 and 4 cores)	1
CY 37001040	4	Core holder (3 and 4 cores)	1
CY 37001050	4	Core holder (1 core)	1
CY 37001060	4	Core holder (2, 3 and 4 cores)	1
CY 15555601	5	End plate gasket (red)	1
CY 15555200	6	Adhesive gasket for core holders: CY 37001030, CY 37001040, CY 37001050, CY 37001060	1
CCY A 48	7	Adapter for end core holder	1
CY 15555000		Bag of gaskets for shell end plates: CARLY and for most manufacturers (gaskets: 122 x 114 x 1.6 and 114 x 103 x 1.6)	1

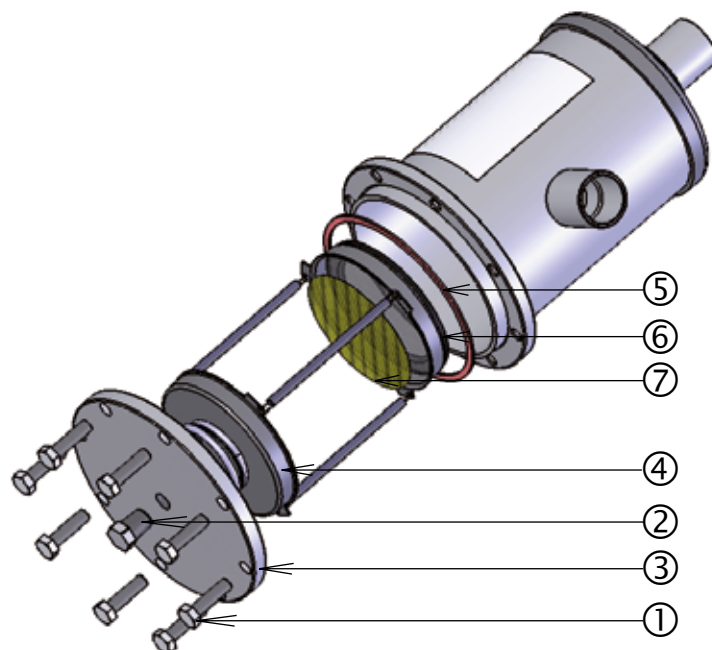



Replaceable core filter shells (suction line)

→ **ACY** (corresponding cores: CCY 48 and PLATINIUM 48)

■ Weights and packaging

CARLY references	Unit weight kg		Packaging number of pieces
	With packaging	Without packaging	
ACY 489 S & MMS	4,60	4,35	1
ACY 4811 S/MMS	4,70	4,45	1
ACY 4813 S & MMS	4,85	4,60	1
ACY 4817 S/MMS	5,05	4,80	1
ACY 4821 S & MMS	5,45	5,20	1
ACY 4825 S & MMS	5,75	5,50	1

CARLY references	Unit weight kg		Packaging number of pieces
	With packaging	Without packaging	
ACY 9617 S/MMS	6,70	6,40	1
ACY 9621 S & MMS	6,85	6,55	1
ACY 9625 S & MMS	7,15	6,85	1
ACY 19217 S/MMS	8,90	8,50	1
ACY 19221 S & MMS	9,60	9,20	1
ACY 19225 S & MMS	9,90	9,50	1



CTCY-EN - 6.1-9 / 09-2023

Replaceable core filter shells (suction line)

→ **BACY** (corresponding cores: CCY 100)

■ Core replacement procedure

- 1 • Isolate the **BACY** suction filter shell.
- 2 • Purge the installation up to atmospheric pressure (shell should be empty of refrigerant)
- 3 • Remove the end plate.
- 4 • Remove the core holders one after the other.
- 5 • Remove the used cores.
- 6 • Clean very carefully the core holders, the **CCY A 100** adapter and the inner part of the shell.
- 7 • Replace systematically the gasket on the end plate and check core holders gaskets.
- 8 • Remove the core from its can and put it on the core holder, separating by means of traction, if necessary, the two flanges that hold the core holder (sketch 1), install the **CCY A 100** adapter in the end core holder.
- 9 • Repeat the operation for each core holder.
- 10 • Quickly install the core holders with their cores in the shell, complying with their mounting order: the first one holds the screen and the adapter, if any, and the last one is equipped with a compression spring (sketch 2)
- 11 • Reinstall the closing flange making sure that the compression spring is correctly positioned and gradually and uniformly tighten the closing screws (refer to chapter 115 – **GENERAL MOUNTING PRECAUTIONS** – Criss-cross tightening). Maximum bolt tightening torque: 55 N.m.
- 12 • Make sure that the end plate 1/4" NPT taper tapping has been properly plugged in and sealed.
- 13 • Make vacuum in the installation and check air-tightness of the whole set before putting back under pressure.

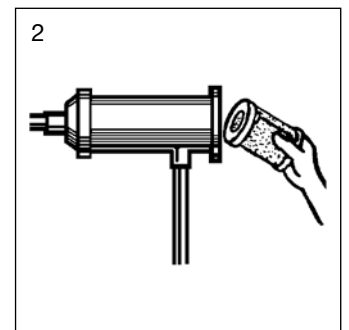
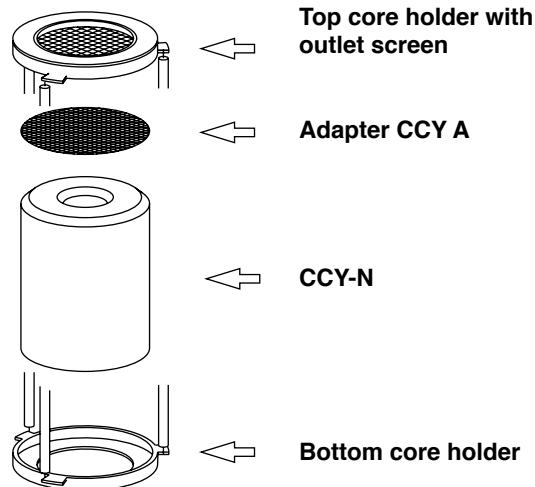
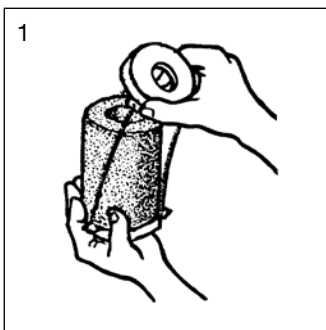



Replaceable core filter shells (suction line)

➔ **BACY** (corresponding cores: CCY 100)

■ Selection table

CARLY references	Connections To solder ODF		Refrigerating capacity kW ⁽¹⁾					Refrigerating capacity kW ⁽¹⁾					Number of cores
			Temporary use with CCY 100 N - CCY 100 F					Permanent use with CCY 100 I					
			R22 R407F R407C R404A R448A R449A R452A R507A	R134a R513A R450A R1234ze	R1233zd	R410A	R744	R22 R407F R407C R404A R448A R449A R452A	R134a R513A R450A R1234ze	R1233zd	R410A	R744 ⁽²⁾	
inch	mm												
BACY 10021 S	2 5/8		96	88	12	125	166	221	202	22	186	248	1
BACY 10021 MMS		67,0	96	88	12	125	166	221	202	22	186	248	1
BACY 10025 S	3 1/8		108	99	14	140	173	230	210	23	209	258	1
BACY 10025 MMS		80,0	108	99	14	140	173	230	210	23	209	258	1
BACY 10029 S	3 5/8		139	127	18	181	227	301	274	30	269	338	1
BACY 10029 MMS		88,9	139	127	18	181	227	301	274	30	269	338	1
BACY 10033 S	4 1/8		191	175	25	248	304	404	368	40	370	453	1
BACY 10033 MMS		108,0	191	175	25	248	304	404	368	40	370	453	1
BACY 20025 S	3 1/8		143	130	19	186	236	313	285	31	277	351	2
BACY 20029 S	3 5/8		183	166	24	238	299	398	363	40	354	446	2
BACY 20029 MMS		88,9	183	166	24	238	299	398	363	40	354	446	2
BACY 20033 S	4 1/8		255	232	33	332	399	530	482	53	494	594	2
BACY 20033 MMS		108,0	255	232	33	332	399	530	482	53	494	594	2
BACY 40033 S	4 1/8		293	266	38	381	504	670	610	67	568	751	4
BACY 40033 MMS		108,0	293	266	38	381	504	670	610	67	568	751	4

⁽¹⁾ Refrigerating capacities according to Standard ARI 730-2001 for To = 4.4 °C, Tk = 32 °C.
If different conditions, refer to correction factors in chapter 112.

⁽²⁾ Refrigerating capacities Qn for Tk = - 10 °C and To = - 40 °C
If different conditions, refer to correction factors in chapter 112.

Nota: the diameter of connections must not be inferior to the diameter of the main pipe.



Replaceable core filter shells (suction line)

→ **BACY** (corresponding cores: CCY 100)

■ Technical features

CARLY references		Connection types ⁽¹⁾	Filtering surface cm ²	Dimensions mm						
				Ø1	Ø2 ⁽²⁾	Ø3	L1	L2	E1	E2
BACY 10021 S	BACY 10021 MMS	3	630	152	156	200	384	300	246	138
BACY 10025 S	BACY 10025 MMS	3	630	152	156	200	394	300	255	130
BACY 10029 S	BACY 10029 MMS	3	630	152	156	200	398	300	260	141
BACY 10033 S	BACY 10033 MMS	3	630	152	156	200	404	300	266	144
BACY 20025 S		3	1260	152	156	200	564	300	422	130
BACY 20029 S	BACY 20029 MMS	3	1260	152	156	200	568	300	426	141
BACY 20033 S	BACY 20033 MMS	3	1260	152	156	200	574	300	432	144
BACY 40033 S	BACY 40033 MMS	3	2520	152	156	200	933	470	780	144

⁽¹⁾ Chapter «Connection features and drawings» (refer to chapter 114).

⁽²⁾ Including weld

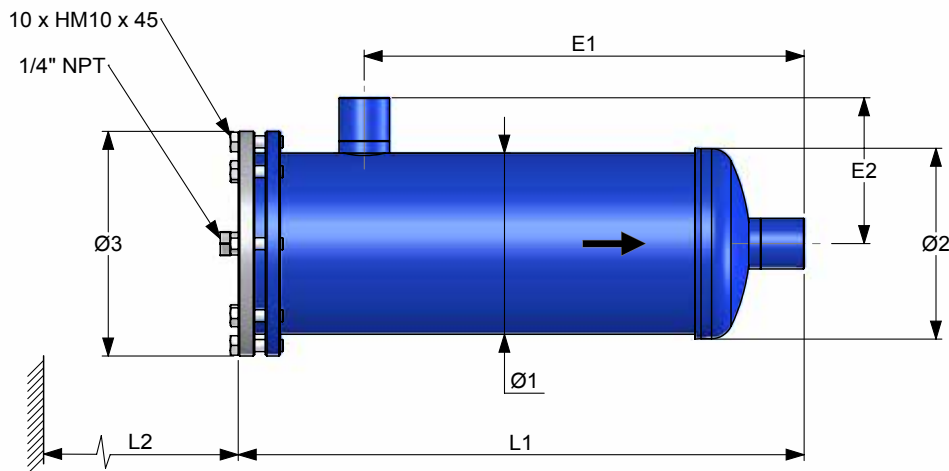

CARLY references		Volume V L	Maximal working pressure PS bar	Working pressure ⁽¹⁾ PS BT bar	Maximal working temperature TS maxi °C	Minimal working temperature TS mini °C	Working temperature ⁽¹⁾ TS BT °C	CE Category ⁽²⁾
BACY 10025 S	BACY 10025 MMS	4,90	33	15	80	-40	-30	I
BACY 10029 S	BACY 10029 MMS	5,00	33	15	80	-40	-30	I
BACY 10033 S	BACY 10033 MMS	5,30	33	15	80	-40	-30	I
BACY 20025 S		7,40	25 *	15	80	-40	-30	I
BACY 20029 S	BACY 20029 MMS	7,50	25 *	15	80	-40	-30	I
BACY 20033 S	BACY 20033 MMS	7,80	25 *	15	80	-40	-30	I
BACY 40033 S	BACY 40033 MMS	13,80	33	15	80	-40	-30	II

⁽¹⁾ The working pressure is limited to the PS BT value when working temperature is lower than or equal to TS BT value.

⁽²⁾ Classification by volume, according to PED 2014/68/EU (refer to chapter 0).

* 33 bar working pressure possible on demand.



Replaceable core filter shells (suction line)

→ BACY (corresponding cores: CCY 100)

■ Spare parts

Shells	CARLY References for core holders	Quantity and type of gaskets for use	
		Core holders gasket ⁽¹⁾	End plate gasket ⁽²⁾
BACY 1 Core	CY 37003055	1 Gasket CY 15555620	
BACY 2 Cores	CY 37003030 + CY 37003065	2 Gaskets CY 15555620	1 Gasket CY 15555701
BACY 3 Cores	CY 37003030 + CY 37003040 + CY 37003065	3 Gaskets CY 15555620	
BACY 4 Cores	CY 37003030 + CY 37003040 + CY 37003085	4 Gaskets CY 15555620	

⁽¹⁾ Gasket delivered with core holders

⁽²⁾ Gasket delivered with cores CCY 100 HP, CCY 100 N, CCY 100 I and CCY 100 F

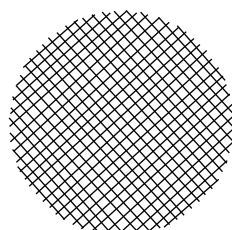
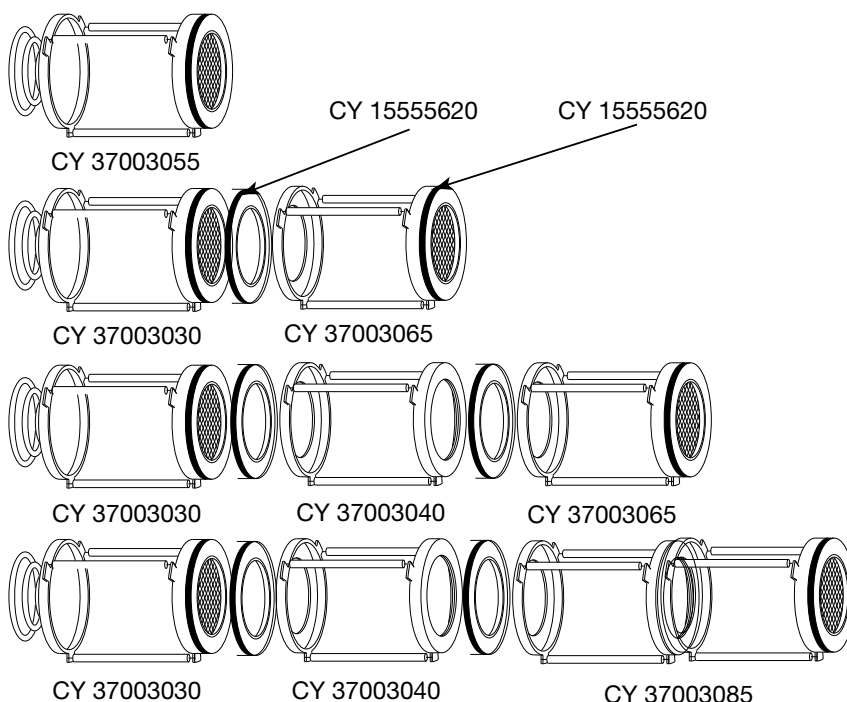

- Outlet filter adapter for BACY:
CCY A 100 (To use with cores CCY 100 HP and CCY 100 N)
- The adapter **CCY A 100** shall be installed in top flange of core holder CY37003055 for one core BACY and CY 37003065 and CY 37003085 and for several cores BACY.



Replaceable core filter shells (suction line)

→ **BACY** (corresponding cores: CCY 100)

■ Spare parts

CARLY references	Part N°	Description	Quantity
CY 19900520	1	Set of 10 fastening screws for end plate	1
CY 10810010	2	1/4" NPT phosphate plug for end plate	1
CY 33301700	2 + 3 + 5	End plate with gasket and 1/4" NPT plug	1
CY 37003030	4	Core holder (2, 3 and 4 cores)	1
CY 37003040	4	Core holder (3 and 4 cores)	1
CY 37003055	4	Core holder (1 core)	1
CY 37003065	4	Core holder (2 and 3 cores)	1
CY 37003085	4	Core holder (4 cores)	1
CY 15555701	5	End plate gasket (red)	1
CY 15555620	6	Adhesive gasket for core holders: CY 37003030 - CY 37003040 - CY 37003055 - CY 37003065 - CY 37003085	1
CCY A 100	7	Adapter for end core holder	1

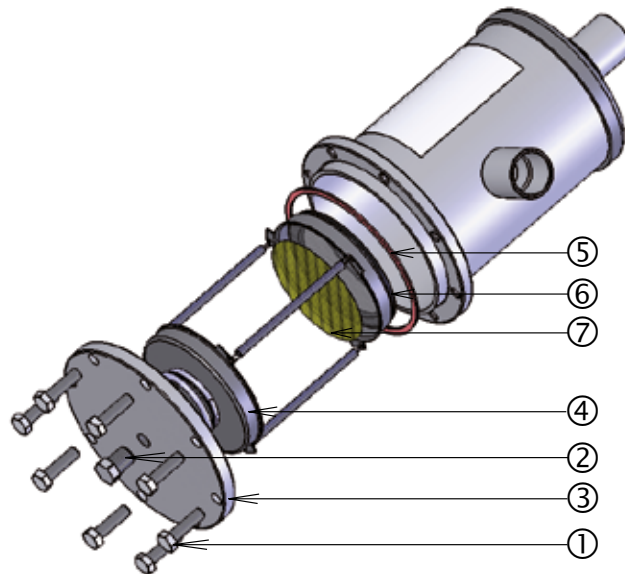

■ Weights and packaging

CARLY references	Unit weight kg		Packaging number of pieces
	With packaging	Without packaging	
BACY 10021 S & MMS	13,30	12,70	1
BACY 10025 S & MMS	13,40	12,80	1
BACY 10029 S & MMS	13,50	12,90	1
BACY 10033 S & MMS	14,40	13,80	1
BACY 20025 S	16,40	15,70	1
BACY 20029 S & MMS	16,60	15,90	1
BACY 20033 S & MMS	16,90	16,20	1
BACY 40033 S & MMS	23,80	22,90	1