

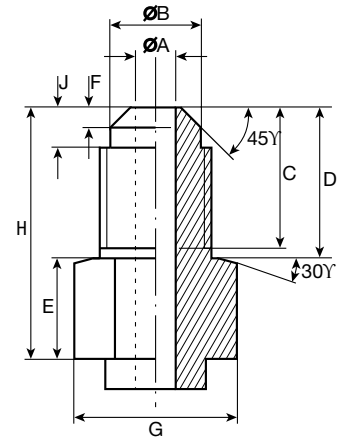

Disegni e caratteristiche degli attacchi

→ ATTACCHI TIPO 1

Attacchi da avvitare pollice	Taglia CARLY	Numero di filetti pollice	Dimensioni mm								
			ØA	ØB	C	D	E	F	G	H	J
1/4 SAE	2	7/16 - 20	4	9	13	15	10	2,0	14	25	4
3/8 SAE	3	5/8 - 18	7	13	17	18	10	2,5	17	28	5
1/2 SAE	4	3/4 - 16	10	16	19	20	10	2,5	22	30	5
5/8 SAE	5	7/8 - 14	13	18	22	23	9	2,3	24	32	5
3/4 BSP	6	1 1/6 - 14	17	23	24	25	11	2,5	30	36	5



→ ATTACCHI TIPO 2 (in pollice)

Attacchi da saldare ODF pollice	Taglia CARLY	Dimensioni mm							
		ØA	ØB	ØC	D	E	F	G	H
1/4	2	4,3	6,40	9,40	6	14	12	5	20
3/8	3	8,0	9,60	12,60	9	14	12	6	20
1/2	4	10,0	12,80	15,80	10	22	13	5	20
5/8	5	14,0	16,10	18,95	16	22	13	7	22
3/4	6	17,0	19,15	22,10	17	27	15	8	25
7/8	7	20,0	22,30	25,30	19	34	21	7	32
1		24,0	25,50	28,50	24	34	26	8	37

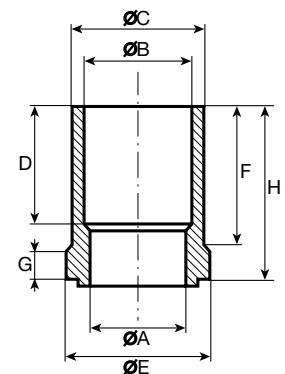

→ ATTACCHI TIPO 2 (in mm)

Attacchi da saldare ODF mm	Taglia CARLY	Dimensioni mm							
		ØA	ØB	ØC	D	E	F	G	H
6	2	4,3	6,1	9,40	6	14	12	5	20
10	3	8,0	10,1	12,60	9	14	12	6	20
12	4	10,0	12,1	15,80	10	22	13	5	20
16	5	14,0	16,1	18,95	16	22	13	7	22
18	6	17,0	18,1	22,10	17	27	15	8	25
22	7	20,0	22,1	25,30	19	34	21	7	32

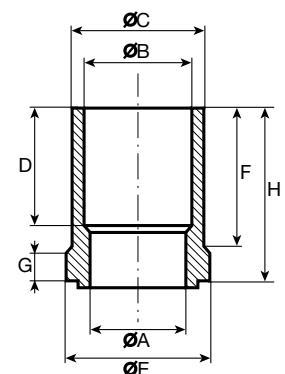



Disegni e caratteristiche degli attacchi

→ ATTACCHI TIPO 3 (in pollice)

Attacchi da saldare ODF pollice	Taglia CARLY	Dimensioni mm				
		ØA	ØB	ØC	D	H
1 1/8	9	26,0	28,7	34,0	24	37
1 3/8	11	32,0	35,0	40,0	30	47
1 5/8	13	38,0	41,4	45,0	30	47
2 1/8	17	52,3	54,1	60,3	35	62
2 5/8	21	66,1	66,8	76,1	38	74
3 1/8	25	76,3	79,5	88,8	45	85
3 5/8	29	89,0	92,2	101,6	55	92
4 1/8	33	101,7	104,9	114,3	55	100
5 1/8		127,1	130,3	139,7	55	100

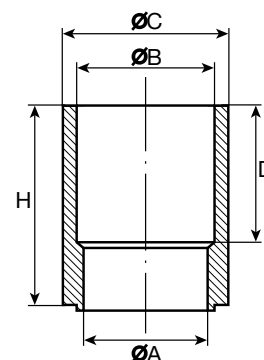

→ ATTACCHI TIPO 3 (in mm)

Attacchi da saldare ODF mm	Taglia CARLY	Dimensioni mm				
		ØA	ØB	ØC	D	H
28	9	26,0	28,1	34,0	24	37
35	11	32,0	35,1	40,0	30	47
42	13	38,4	42,1	48,3	30	47
54	17	52,0	54,1	60,3	35	62
67	21	66,0	67,1	76,1	38	74
80	25	79,0	80,1	88,8	45	85
88.9	29	90,0	89,0	101,6	55	92
108	33	102,0	108,1	114,3	55	100
130		127,1	130,1	139,7	55	100

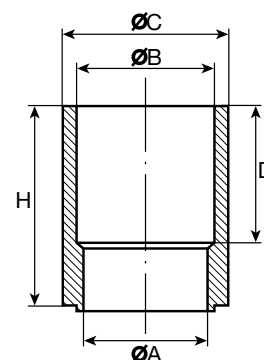



Disegni e caratteristiche degli attacchi

→ ATTACCHI TIPO 4 (in pollice e in mm)

Attacchi da saldare ODF		Taglia CARLY	Dimensioni mm					
pollice	mm		ØA	ØB1	ØB2	ØC	D1	D2
1/4	6	2	5,5	6,4	6,1	11,0	6	10
3/8	10	3	8,0	10,1	9,6	14,2	6	10
1/2	12	4	10,0	12,8	12,1	19,0	8	12

Preparazione delle estremità degli attacchi per:

- Saldatura delle estremità secondo EN 10253
- Brasatura secondo EN 1254

Attacchi in acciaio carbonio - Gruppo 1 o 11 secondo EN 15608

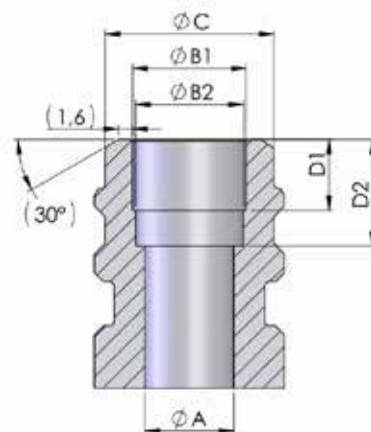

→ ATTACCHI TIPO 5 (in pollice e in mm)

Attacchi da saldare ODF		Taglia CARLY	Dimensioni mm			
pollice	mm		ØA	ØB	ØC	D
5/8	16	5	15,0	16,1	20,6	12
3/4	-	6	17,0	19,2	28,0	16
7/8	22	7	20,0	22,3	28,0	18
1 3/8	35	11	32,4	35,1	44,0	30

Preparazione delle estremità degli attacchi per:

- Saldatura delle estremità secondo EN 10253
- Brasatura secondo EN 1254

Attacchi in acciaio carbonio - Gruppo 1 o 11 secondo EN 15608

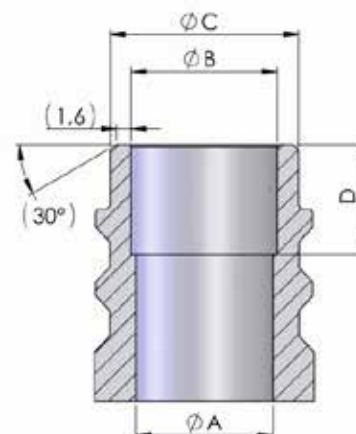

→ ATTACCHI TIPO 6 (in pollice e in mm)

Attacchi da saldare ODF		Taglia CARLY	Dimensioni mm			
pollice	mm		ØA	ØB	ØC	D
1 1/8	28	9	24,0	28,7	35,0	20
		9	24,0	28,1	35,0	20
1 5/8	54	13	32,0	41,4	47,9	30
2 1/8		17	51,0	54,2	64,5	35

Preparazione delle estremità degli attacchi per:

- Saldatura delle estremità secondo EN 10253
- Brasatura secondo EN 1254

Attacchi in acciaio carbonio - Gruppo 1 o 11 secondo EN 15608

